

**CITY OF MOLALLA
PUBLIC WORKS
DESIGN STANDARDS**

SECTION	1.0000 - GENERAL	1-1
	1.0010 - AUTHORITY AND PURPOSE	1-1
	1.0020 - ENGINEERING POLICY	1-1
	1.0030 - APPLICABILITY	1-1
	1.0040 - STANDARD SPECIFICATIONS	1-1
	1.0050 - APPROVAL OF ALTERNATE MATERIALS OR METHODS	1-2
	1.0060 - SPECIAL DESIGN PROBLEMS	1-2
	1.0070 - REVISIONS TO DESIGN STANDARDS	1-2
	1.0080 - DEFINITIONS	1-2
	1.0090 - CONSTRUCTION PLANS	1-7
	1.0091 - GENERAL INFORMATION.	1-7
	1.0100 - PLAN PREPARATION	1-7
	1.0101 - SHEET SIZE	1-7
	1.0102 - SETS OF PLANS	1-7
	1.0130 - REQUIRED SHEETS	1-8
	1.0131 - TITLE SHEET	1-8
	1.0132 - PLAN SHEET	1-8
	1.0133 - PROFILE SHEET.	1-9
	1.0134 - DETAIL SHEETS	1-9
	1.0140 - SUPPORTING INFORMATION	1-10
	1.0141 - UTILITY PLAN	1-10
	1.0150 - PLAN SUBMITTAL	1-10
	1.0160 AS-BUILT PLAN REQUIREMENTS	1-10
	1.0161 - STREET	1-11
	1.0162 - STORM DRAINS	1-11
	1.0163 - SANITARY SEWER	1-11
	1.0164 - WATER MAIN	1-11
SECTION	2.0000 - EXCAVATION AND GRADING	2-1
	2.0010 - PURPOSE	2-1
	2.0020 - SCOPE	2-1
	2.0030 - PERMITS REQUIRED	2-1
	2.0040 - HAZARDS	2-2
	2.0050 - DEFINITIONS	2-2
	2.0060 - GRADING PERMIT REQUIREMENTS	2-3
	2.0080 - BONDS	2-5
	2.0090 - CUTS	2-5

	2.0100 - FILLS	2-5
	2.0110 - SETBACKS	2-6
	2.0120 - DRAINAGE AND TERRACING	2-6
	2.0130 - EROSION CONTROL	2-7
	2.0140 - GRADING INSPECTION	2-7
	2.0150 - COMPLETION OF WORK	2-8
SECTION	3.0000 - STORM DRAINAGE	3-1
	3.0010 - GENERAL DESIGN REQUIREMENTS	3-1
	3.0011 - SITE DRAINAGE PLANS	3-2
	3.0012 - PIPE MATERIALS AND SIZE	3-3
	3.0013 - MINIMUM DESIGN CRITERIA	3-3
	3.0020 - ALIGNMENT AND COVER	3-4
	3.0021 - RIGHT-OF-WAY LOCATION	3-4
	3.0022 - CURVATURE	3-4
	3.0023 - MINIMUM COVER	3-4
	3.0024 - EASEMENTS	3-4
	3.0025 - RELATION TO WATERCOURSES	3-5
	3.0030 - STRUCTURE LOCATION	3-5
	3.0031 - MANHOLES	3-5
	3.0032 - CATCH BASINS	3-5
	3.0033 - DRY WELLS	3-6
	3.0034 - ANCHOR BLOCKS	3-6
	3.0035 - WATER BARS	3-6
	3.0040 - STORM DETENTION	3-6
	3.0041 - DEVELOPMENT NOT REQUIRING DETENTION	3-6
	3.0043 - DETENTION VOLUME	3-6
	3.0044 - EMERGENCY OVERFLOW	3-6
	3.0045 - DETENTION FACILITIES	3-7
	3.0050 - EROSION CONTROL	3-7
	3.0051 - EROSION CONTROL - APPLICATION	3-7
	3.0060 - PRIVATE DRAINAGE SYSTEMS	3-7
	3.0061 - SUBDIVISIONS	3-7
	3.0062 - SUBSURFACE DRAINAGE	3-7
	3.0070 WATER QUALITY	3-8
SECTION	4.0000 - SANITARY SEWERS	4-1
	4.0010 - GENERAL DESIGN REQUIREMENTS	4-1
	4.0011 - PIPE MATERIALS AND SIZE	4-1
	4.0012 - MINIMUM DESIGN CRITERIA	4-2
	4.0020 - ALIGNMENT AND COVER	4-2
	4.0021 - RIGHT OF WAY LOCATION	4-2
	4.0022 - MINIMUM COVER	4-2
	4.0023 - SEPARATION WITH WATER LINES	4-3
	4.0024 - EASEMENTS	4-3
	4.0025 - RELATION TO WATERCOURSES	4-3

	4.0030 - STRUCTURES	4-3
	4.0031 - MANHOLES	4-3
	4.0032 - CLEAN OUTS	4-5
	4.0033 - ANCHOR BLOCKS	4-5
	4.0034 - WATER BARS	4-5
	4.0040 - SERVICE LATERAL	4-6
	4.0050 - CONNECTION TO EXISTING SEWERS	4-6
	4.0060 - PRIVATE SEWER LINES	4-7
	4.0070 - SYSTEM TESTING	4-7
	4.0080 - SEWAGE PUMP STATION DESIGN STANDARDS	4-7
	4.0081 - GENERAL	4-7
	4.0082 - CONSTRUCTION	4-7
	4.0083 - CAPACITIES	4-7
	4.0084 - HYDROGEN SULFIDE	4-7
	4.0085 - ELECTRICAL	4-7
	4.0086 - MATERIALS	4-8
	4.0087 - ADDITIONAL FEATURES	4-8
	4.0088 - OPERATING AND MAINTENANCE DATA	4-8
	4.0090 - EROSION CONTROL	4-9
SECTION	5.0000 - WATER MAINS	5-1
	5.0010 - GENERAL DESIGN REQUIREMENTS	5-1
	5.0011 - PIPE MATERIALS AND SIZE	5-1
	5.0012 - GRID SYSTEM	5-2
	5.0013 - DEAD-END MAINS	5-2
	5.0020 - ALIGNMENT AND COVER	5-2
	5.0021 - RIGHT-OF-WAY LOCATION	5-2
	5.0022 - MINIMUM COVER	5-3
	5.0023 - SEPARATION WITH SEWER LINES	5-3
	5.0024 - EASEMENTS	5-3
	5.0025 - RELATION TO WATERCOURSES	5-3
	5.0030 - APPURTENANCES	5-4
	5.0031 - VALVES	5-4
	5.0032 - FIRE HYDRANTS	5-4
	5.0033 - PRESSURE-REDUCING AND AIR RELEASE VALVES	5-5
	5.0034 - RAILROAD OR HIGHWAY CROSSINGS	5-5
	5.0035 - ANCHOR BLOCKS	5-5
	5.0036 - WATER BARS	5-6
	5.0040 - BACKFLOW PREVENTION	5-6
	5.0050 - WATER SERVICE LINES	5-6
	5.0060 - SYSTEM TESTING	5-6
	5.0070 - EROSION CONTROL	5-6
SECTION	6.0000 - STREETS	6-1
	6.0010 - GENERAL DESIGN REQUIREMENTS	6-1
	6.0011 - RIGHT-OF-WAY AND PAVEMENT WIDTH	6-1
	6.0012 - ACCESS	6-1
	6.0013 - TRAFFIC ANALYSIS	6-2
	6.0014 - INTERSECTIONS	6-3
	6.0015 - HALF-STREET CONSTRUCTION	6-4
	6.0016 - STREET CLASSIFICATION	6-4
	6.0017 - DESIGN SPEED	6-5

6.0020 - HORIZONTAL/VERTICAL CURVES, AND GRADES	6-5
6.0021 - HORIZONTAL CURVES	6-5
6.0022 - VERTICAL CURVES	6-5
6.0023 - GRADES	6-5
6.0024 - STREETS - EXISTING	6-6
6.0025 - STREETS - NAMES	6-6
6.0026 - STREETS - ADJACENT TO RAILROAD RIGHT-OF-WAY	6-6
6.0027 - STREETS - MARGINAL ACCESS	6-6
6.0030 - PAVEMENT DESIGN	6-6
6.0040 - CONCRETE CURB	6-6
6.0041 - CURB RETURN RADIUS	6-7
6.0050 - PARKING	6-7
6.0060 - SIDEWALKS	6-9
6.0061 - WHEELCHAIR RAMPS	6-9
6.0070 - BIKEWAYS	6-9
6.0071 - BIKEWAY LOCATION, WIDTH	6-10
6.0072 - DESIGN CRITERIA	6-10
6.0073 - CONSTRUCTION	6-10
6.0074 - LIGHTING	6-11
6.0075 - DETERRING MOTOR VEHICLE USE	6-11
6.0080 - DRIVEWAYS	6-11
6.0090 - STREET LIGHTING, NAMES AND SIGNAGE	6-12
6.0091 - STREET LIGHTING	6-12
6.0092 - STREET NAMES AND TRAFFIC CONTROL	6-13
6.0100 - MAILBOXES	6-13
6.0110 - STREET SYSTEM DESCRIPTION AND FUNCTION	6-13
6.0111 - GENERAL GUIDELINES	6-13
6.0112 - FUNCTIONAL CLASSIFICATIONS	6-13
6.0120 - PERMANENT DEAD-END STREETS	6-14
6.0130 - ALLEYWAYS AND PRIVATE RESIDENTIAL STREETS/ACCESS WAYS	6-14
6.0131 - ALLEYWAYS	6-14
6.0132 - PRIVATE RESIDENTIAL ACCESS WAYS	6-14
6.0133 - PAVEMENT CUTS	6-15
6.0134 - SHOULDERS	6-15
SECTION 7.0000 - PERMIT	7-1
7.0010 - APPLICATION FOR PERMIT	7-1
7.0011 - APPLICATION	7-1
7.0012 - PERMIT FEES	7-1
7.0013 - EXPIRATION	7-1
7.0015 - PENALTY	7-2
7.0016 - RIGHT OF APPEAL	7-2
7.0017 - PLANS	7-2

7.0020 - INSPECTIONS	7-2
7.0021 - GENERAL	7-2
7.0022 - INSPECTIONS FOR RIGHT-OF-WAY IMPROVEMENTS	7-2
7.0022 - INSPECTION RECORD CARD	7-2
7.0023 - INSPECTION REQUESTS	7-3
7.0025 - REQUIRED INSPECTIONS	7-3
7.0030 - INSPECTIONS	7-3
7.0031(a) - INSPECTIONS BY THE CITY	7-3

CITY OF MOLALLA PUBLIC WORKS DESIGN STANDARDS

SECTION 1.0000 - GENERAL

1.0010 - AUTHORITY AND PURPOSE

The Molalla Comprehensive Plan addresses land use and development issues within the City. This comprehensive planning document is a single document with references to many Ordinances. The Molalla Comprehensive Plan and Subdivision Ordinance regulates the divisions of land and the creation of public facilities. The "Design Standards" section of the Subdivision Ordinance, discusses generalized public facility design requirements.

The purpose of these Design Standards is to provide a consistent policy under which certain physical aspects of public facility design will be implemented. Most of the elements contained in this document are Public Works oriented and it is intended that they apply to both public improvements under City contract and public improvements under private contract designated herein.

These Design Standards cannot provide for all situations. They are intended to assist but not to substitute for competent work by design professionals. It is expected that engineers will bring to each project the best of skills from their respective disciplines.

The Design Standards are also not intended to limit unreasonably any innovative or creative effort which could result in better quality, better cost savings, or both. Any proposed departure from the Design Standards will be judged, however, on the likelihood that such variances will produce compensating or comparable result, in every way adequate for the user and City residents.

Alternate materials and methods will be considered for approval by the Public Works Director as the need arises and conditions warrant modification. This consideration will be on a case-by-case basis and require sufficient justification prior to approval. (See Section 1.0050)

1.0020 - ENGINEERING POLICY

It shall be the policy of the City of Molalla to require compliance with Oregon Revised Statute Chapter 672 for professional engineers.

All engineering plans, reports, or documents shall be prepared by a registered professional engineer, or by a subordinate employee under the engineer's direction, and shall be signed by the engineer and stamped with the engineer's seal to indicate the engineer's responsibility for them. It shall be the engineer's responsibility to review any proposed public facility extension, modification or other change with the City, prior to engineering or proposed design work, to determine any special requirements or whether the proposal is permissible. A "Preliminary Review" and/or a "Plans Approved for Construction" stamp of the City, on the plans, etc., for any job, does not in any way relieve the engineer of responsibility to meet all requirements of the City or obligation to protect life, health, and property of the public. The plan for any project shall be revised or supplemented at any time it is determined that the full requirements of the City have not been met.

1.0030 - APPLICABILITY

These Design Standards shall govern all construction and upgrading of all public and privately financed public facilities in the City of Molalla and applicable work within its service areas.

1.0040 - STANDARD SPECIFICATIONS

Except as otherwise provided by these Design Standards, all construction design detail, workmanship and materials shall be in accordance with the current edition of the APWA Standard Specifications for Public Works Construction, Oregon Chapter except Drawing #206 for wheelchair and bicycle ramps, which shall conform to ADA Standards.

1.0050 - APPROVAL OF ALTERNATE MATERIALS OR METHODS

Any substitution material or alternate method not explicitly approved herein will be considered for approval as set forth in Section 1.0010. Persons seeking such approvals shall make application in writing. Approval of any deviation from these Design Standards will be in written form. Approval of minor matters will be made in writing if requested.

Any alternate must meet or exceed the minimum requirements set in these Design Standards.

The written application is to include, but is not limited to, the manufacturer's specifications and testing results, design drawings, calculations, reason and justification, and other pertinent information.

Any deviations or special problems shall be reviewed on a case-by-case basis and approved by the Public Works Director. When requested by the City, full design calculations shall be submitted for review with the request for approval.

1.0060 - SPECIAL DESIGN PROBLEMS

Special applications not covered in these Design Standards require review and approval by the Public Works Director. Submittal of full design calculations, supplemental drawings and information will be required prior to any approval.

Applications requiring special review and approval may include, but are not limited to, the following:

Sewer Force Mains	Water Distribution Pump Stations
Relining of Existing Sewers	Relining of Existing Water Mains
Internal Sealing of Existing Sewers	Water Pressure Regulating Devices
Sewer Regulatory Devices	Energy Dissipaters
Sewage Pump Stations	Water Reservoirs
Sewer Siphons	Water Treatment Plants
Sewage Treatment Plants	Water Flow Measurement/Monitoring
Sewer Flow Measurement/Monitoring Device	Stormwater Facilities
	Stormwater detention Facilities

1.0070 - REVISIONS TO DESIGN STANDARDS

It is anticipated that revisions to these Design Standards will be made from time to time. The date appearing on the bottom of each page is the date of the latest revision. Users should apply the latest published issue to the work contemplated.

Parenthetical notations at the end of sections indicate the most recent change to those sections. All sections without notations are from the original Design Standards as adopted. Some sections may be changed more than once and it shall be the user's responsibility to maintain his/her copy of these Design Standards with the latest changes.

1.0080 - DEFINITIONS

Alley - A public access easement or right-of-way not more than 20 feet and not less than 12 feet in width, which intersects with a public street.

Approved Back flow Prevention Device - A device that has been investigated and approved by the Oregon State Health Division.

Arterial Street - A street intended to carry large volumes of traffic at steady speeds with minimum interruptions to traffic flow.

As-Built Plans - Plans signed and dated by the project engineer indicating that the plans have been reviewed and revised, if necessary, to accurately show all as-built construction details and changes.

Back flow - The flow of water or other liquids, mixtures, or substances into the distributing pipes of a potable supply of water from any sources other than its intended source.

Back flow Preventer - A device or means to prevent back flow into the potable water system.

Back Siphonage - The flowing back of used, contaminated, or polluted water from a plumbing fixture or vessel into a water supply pipe due to a negative pressure in such pipes.

Bike Lanes - A designated travel-way for bicyclists which is located within the roadway directly adjacent to the outside vehicular lane or on the shoulder.

Bike Path - A designated travel-way for bicycling which is completely separated from the vehicular travel lanes and is within independent right-of-ways.

Bike Route - A designated travel-way for bicyclist which is shared with vehicular traffic. The roadway is designated with signs for bicycling (no pavement markings for the bike route or delineation of parking spaces are used).

Building Service Lateral - A public sanitary sewer beginning at the property line or public easement line and extending to the sanitary sewer main.

Building Sewer - A private sanitary sewer beginning five (5) feet outside the building and extending to the property line or public easement line, connecting to the building service lateral.

Building Supply - The pipe carrying potable water from the water meter or other source of water supply to a building or other point of use or distribution on the lot. Building supply shall also mean customer line.

City - The City of Molalla, Oregon.

Public Works Director - The individual (a registered professional engineer) designated to have the authority to review and approve all public works design and construction projects.

Collection Systems - Facilities maintained by the City of Molalla connected thereto for the collecting, pumping, conveying, and controlling of wastewater.

Collector Sewer - The portion of the public sewerage system which is primarily installed to receive waste water directly from individual residences and other individual public or private structures.

Collector Street - Street which forms the boundary of major blocks of land and is intended primarily for inter-neighborhood traffic; can function as a road to service areas from the arterial system.

Core - To cut and remove a circular portion of concrete, pavement, pipe or soil.

Cross Connection - Any connection or arrangement, physical or otherwise, between a potable water supply system and any plumbing fixture or any tank, receptacle, equipment or device, through which it may be possible for non potable, used, unclean, polluted and contaminated water, or other substances, to enter into any part of such potable water system under any condition.

Cul-de-sac - A dead-end street having a turnaround area at the end.

Curb - The line indicating the edge of the vehicular roadway within the overall right-of-way.

Cut Sheets - Sheets of tabulated data, indicating stationing, structures, fittings, angle points, beginning of curve, points on curve, end of curves, storm drain slope, staking offset, various elevations, offset cuts, and storm drain depths for streets, water lines, sanitary sewers, and storm drains.

Datum - The vertical elevation control for the City of Molalla is based on Oregon Department of Transportation datum.

Dead-end Street - A street or series of streets which can be accessed from only one point. Dead-end streets can be either temporary (intended for future extension as part of a future street plan) or permanent.

Permanent dead-end streets must provide adequate turnaround capability.

Definition of Words - Whenever the words "directed," "required," "permitted," "ordered," "designated," or words of like importance are used in these Standards, they shall be understood to mean the direction, requirement, permission, or order of designation of the Public Works Director. Similarly, the words "approved," "acceptable," or "satisfactory," shall mean approved by, acceptable to, or satisfactory to the Public Works Director.

Designated Arterial or Collector Street - A street designated as an arterial or collector in the Comprehensive Plan.

Detention - The holding of runoff for a short period of time and then releasing it to the natural water course where it returns to the hydrologic cycle.

Domestic Sewage - The liquid and waterborne waste derived from the ordinary living processes, free from industrial wastes, and of such character to permit satisfactory disposal, without special treatment into the public sewer or by means of private sewage disposal system.

Double Check Valve Assembly - An assembly composed of two single, independently acting, approved check valves, including tightly closing shut-off valves located at each end of the assembly and fitted with properly located test cocks.

Double Check Detector Check Valve Assembly - A line-sized approved double check valve assembly with a parallel meter and meter-sized approved double check valve assembly. The purpose of this assembly is to provide Back flow protection for the distribution system and at the same time provide a metering of the fire system showing any system leakage or unauthorized use of water.

Drainage Facilities - Pipes, ditches, detention basins, creeks, culvert bridges, etc., used singularly or in combination with each other for the purpose of conveying or storing storm water runoff.

Easement - Areas located outside of dedicated rights-of-way which are granted to the City for special uses.

Engineer - The engineer, including the City's engineer, Licensed by the State of Oregon as a Professional Engineer under whose direction plans, profiles, and details for the work are prepared and submitted to the City for review and approval, or who is in charge of and responsible for construction management of the improvement.

Expansion Joint - A joint to control cracking in the concrete surface structure and filled with preformed expansion joint filler.

Fire Hydrant Assembly - The fire hydrant and attached auxiliary valve.

Fire Protection Service - A metered connection to the public water main intended only for the extinguishment of fires and the flushing necessary for its proper maintenance.

French Drain or Leach Line - A covered underground excavated trench filled with washed gravel that surrounds a perforated delivery pipe used to receive storm water, wherein the sides and bottom of the trench are porous, permitting the storm water to seep into the ground.

Grade - The degree of inclination of a road or slope.

Hydrant Lead - The water line connecting the fire hydrant to the auxiliary valve on the City distribution main.

Impervious Areas - Those hard surface areas located upon real property which either prevent or retard saturation of water into the land surface and cause water to run off the land surface in greater quantities or at an increased rate of flow from that present under natural conditions preexisting to development.

Industrial Waste - Solid, liquid, or gaseous waste resulting from any industrial, manufacturing, trade, or business process or from development, recovery, or processing of natural resource.

Interceptor Sewer - The primary public sanitary sewer which conveys waste water directly into the Waste Water Treatment Plant.

Irrigation Service - A metered connection intended for seasonal use and delivering water which are not discharged to the sanitary sewer.

Lateral Sewer - A building service lateral.

Local or Residential Street - A street designated to provide vehicular access to abutting properties and discourage through traffic.

Longitudinal Joint - A joint which follows a course approximately parallel to the centerline of the roadway.

Major Partition - A partition which includes the creation of a road or street.

Major Trees - Trees within the right-of-way are those which have a caliper of 4" or larger. Street improvement plans will identify major trees by location, caliper, and species.

Major tree species are those which contribute to the landscape character of the area to include: Douglas Fir, Cedar, Redwood, Sequoia, Oak, Ash, Birch, Walnut, Maple. The identification of major trees should distinguish species generally suitably for retention adjacent to streets and those species with growth habits that create nuisances, unusual maintenance problems, or hazards to the public. Major trees exist in clusters, groves or rows within the right-of-way.

Manufacturer's Name - Any manufacturer's name, specification, catalog, number or type used herein is specified by make and order to establish the standard requirements of the City. Other equivalent makes will be considered for approval, providing they are comparable with this established standard.

Minor Partition - A partition which does not include the creation of a road or a street.

Natural Grade - The grade of the land in an undisturbed state.

On-Site Detention - The storage of excess runoff on the development site prior to its entry into a public storm drain system and gradual release of the stored runoff after the peak of the runoff has passed.

Owner - The owner of record of real property as shown on the latest tax rolls or deed records of the county, and includes a person who furnishes evidence that he/she is purchasing a parcel of property under a written recorded land sale contract.

Partition - To divide an area or tract of land into two or three parcels within a calendar year when such area or tract of land exists as a unit or contiguous units of land under single ownership at the beginning of such year.

Peak Runoff - The maximum water runoff rate (cfs) determined for the design storm.

Person - Individual, firm, corporation, association, agency, or other entity.

Plans - Construction plans, including system plans, sewer plans, and profiles, cross sections, detailed drawings, etc., or reproductions thereof, approved or to be approved by the Public Works Director, which Shows the location, character, dimensions, and details for the work to be done, in which constitute a supplement to these standards

Potable Water - Water which is satisfactory for drinking, culinary, and domestic purposes and meets the requirement of the health authority having jurisdiction.

Private Collection System - A privately owned and maintained sewer system installed to serve multi unit structures on single ownership properties, which cannot legally be further divided.

Private Storm Drain - A storm drain located on private property serving more than one structure on the same premises or parking lot catch basins.

Public Sanitary Sewer - Any sewer located in a public right-of-way or easement and operated and maintained by the City for carrying sewage and industrial wastes.

Public Storm Drain - Any storm sewer located in a public right-of-way or easement and operated and maintained by the City.

Release Rate - The controlled rate of release of drainage, storm, and runoff water from property, storage pond, runoff detention pond, or other facility during and following a storm event.

Right-of-Way - All land or interest therein which by deed, conveyance, agreement, easement, dedication, usage, or process of law is reserved for or dedicated to the use of the public for sidewalk, utility, and/or roadway purposes, which the City has sole responsibility to maintain.

Roadway - All of that portion of the right-of-way used or to be used for vehicle movement which exists between the curbs or proposed curb lines.

Sedimentation - Disposition of erosional debris, soil sediment transported by water from a higher elevation to an area of lower gradient where sediments are deposited as a result of slack water.

Sewage - A combination of the water-carried wastes from residences, business buildings, institutions, and industrial establishments, except industrial wastes.

Sidewalk - A walk or path along the side of a road for pedestrians. A right-of-way deeded, dedicated, and designated for the use of non motorized vehicles and pedestrians.

Silt - Fine textured soil particles including clay and sand as differentiated from coarse particles of sand and gravel.

Siltation - Deposition of (silt) waterborne sediments.

Standard Drawings - The drawings of structures or devices commonly used on public improvements and referred to on construction plans.

Streets or Roads - Any public highway, road, street, avenue, alleyway, easement or right-of-way used or to be used for vehicle movement.

Structures - Those structures designated on the standard plans such as catch basins, manholes, etc.

Subdivision - To divide an area or tract of land into four or more lots within a calendar year when such area or tract of land existed as a unit or contiguous units of land under a single ownership at the beginning of such year.

Super elevation - The vertical distance between the heights of the inner and outer edges of a highway pavement.

Transverse Joint - A joint which follows a course approximately perpendicular to the centerline of the roadway.

Traveled Way - That portion of the roadway for the movement of vehicles, exclusive of shoulder and auxiliary lanes.

Turnaround Area - An area of sufficient size and configuration that a motor vehicle may maneuver so as to travel in the opposite direction.

Trunk Sewer - (Interceptor) A sanitary sewer which is primarily intended to receive waste water from a collector sewer, another trunk sewer, an existing major discharger of raw or inadequately treated wastewater, or water pollution control facility.

Uniform Plumbing Code - The Uniform Plumbing Code adopted by the current edition of the International Association of Plumbing and Mechanical Officials, as revised by the State of Oregon, called the "Oregon State Plumbing Specialty Code."

Waste Water - The total fluid flow in the sanitary sewerage system which includes industrial waste-sewage, or any other waste including that which may be combined with any ground water, surface water, or storm water that may be discharged into the sanitary sewerage system.

Water Distribution System - Water distribution pipelines, pumping stations, valves, and ancillary equipment used to transmit water from the supply source to the service line.

Water Main - The water-supply pipes for public or community use.

Water Service Line - The pipe connection from the City water main to the users' water meter, hydrant, back flow prevention device, or fire sprinkler double check valve.

Wetlands - Those lands adjacent to watercourses or isolated therefrom which may normally or periodically be inundated by the waters from the watercourse or the drainage waters from the drainage basin in which it is located. These include swamps, bogs, sinks, marshes and lakes, all of which are considered to be part of the watercourse and drainage system of the City and shall include the headwater areas where the watercourse first surfaces. They may be, but are not necessarily, characterized by special vegetation or soils such as peat, muck, and mud.

1.0090 - CONSTRUCTION PLANS

1.0091 - GENERAL INFORMATION.

Prior to any construction work and plan approval, complete construction plans, specifications and all other necessary submittals shall be submitted to the Public Works Director for review.

1.0100 - PLAN PREPARATION

Construction plans and specifications shall be prepared as specified in Sections 1.0091 - 1.0134 by a professional engineer licensed in the State of Oregon.

1.0101 - SHEET SIZE

All construction plans shall be clearly and legibly drawn in ink on Mylar sheets measuring 22 x 34 inches. Sheets shall have 1-1/2 inches of clear margin on the left edge and a 1/2 inch margin on all other edges.

1.0102 - SETS OF PLANS

When plans are prepared for developer financed projects, the following scale of drawings is suggested.

<u>Plan/Scale</u>	<u>Horizontal</u>	<u>Vertical</u>
Street	1" = 20'*	1" = 2'
Sewer	1" = 40'	1" = 4'
Storm	1" = 40' or 20'	1" = 4'
Water	1" = 20' or 40'**	1" = 4'

* Subdivision street plans, when combined with other proposed facilities listed above, may be drawn at 1" = 40' scale.

** When a scale is used which is smaller than 1" = 20' (i.e., 1" = 40') intersection details showing fittings and valving shall be provided at a larger scale.

Architectural scales (i.e., 1/4" = 1'-0") are not permitted unless approved.

1.0130 - REQUIRED SHEETS

Construction plan submittals shall contain the following minimum sheets: title sheet (unless not required by the Public Works Director) plan and profile sheets, detail sheets.

1.0131 - TITLE SHEET

All subdivision projects and multiple street improvement projects shall have a title sheet as the first page of the construction plans. This sheet shall contain the following minimum information.

- a. Site plans of the entire project with street right-of-way and/or subdivision layout at a 1" = 100' scale. A 1" = 200' scale may be used if project size is too large. The site plan shall also be a composite utility plan showing all properties served by proposed sewer, water and storm facilities, in addition to the proposed facility and all easements. The site plan shall also include all adjacent public facilities within 100' of the proposed project.
- b. Vicinity map at a 1" = 1000' scale, or greater.
- c. Index of sheets.
- d. Complete legend of symbols used.
- e. General and construction notes pertinent to project.
- f. Temporary and/or permanent bench marks used along with their descriptions, elevations of benchmark and datum.
- g. Engineer's name, address and phone number & seal.
- h. Developer's/owner's name, address and phone number for public improvements with private financing.
- i. Statement referencing City of Molalla Design Standards and the latest edition of the APWA Standard Specifications for Public Works Construction, Oregon Chapter.
- j. Provide contact phone number for all affected utility companies.
- k. Show tax lot numbers or lot and block designations.

1.0132 - PLAN SHEET

The plan view of each sheet shall be drawn at the appropriate scale showing the following minimum information:

- a. Adjacent street curbs, property lines, right-of-way lines, utility easements referenced to property lines, street centerlines and intersections. Show property corner and curb elevations to determine water service level, serviceability of lot/property and sanitary sewer, points of disposal for building storm drains, and how new curbs will join to existing curbs.
- b. Location of all underground utilities within 100 ft. of the project (if they are affected by the project), existing power/telephone poles and guy anchors, valves, manholes, catch basins, fire hydrants, meter boxes and vaults, signs, etc.
- c. Location of all water courses, railroad crossings, culverts, bridges, large water transmission pipes and gravity sewers and/or storm drains within 200 feet of proposed gravity sewer and storm drain extensions if they affect the design of the project. All water courses shall show the 100-year flood plain as indicated on the UPS. Army Corps of Engineers and Federal Emergency Management Agency (F.E.M.A.) maps.

- d. On sewer and storm drain plans, each manhole, catch basin, and clean-out shall be numbered and stationed. Stationing shall tie to existing street monuments, property corners or manholes. Each line shall be stationed continuously upgrade and go from left to right on the plan sheet. Each separate line shall be separately designated (e.g., sewer line 'A', storm line 'A', etc.)
- e. On street plans, horizontal stationing shall show points of tangent and curvature for centerline curve data shall show tangent length, radius distance, centerline curve length, and delta angle. Centerline intersection stationing, in both directions, shall be shown.
- f. Where streets are being widened, edge of pavement elevations shall be shown to determine pavement cross-slope to new curb or pavement edge.
- g. On water plans, all fittings shall be shown and identified by type (i.e., MJ x MJ, FLG X MJ, etc.). Fire hydrants and intersection details for valves and fittings are required when scale of plans is smaller than 1" = 20' (i.e., 1" = 40'). All valves, fittings and pipe conditions shall be indicated.
- h. On erosion control plans, the location of silt fences, inlet barriers, gravel entry ways, temporary ditches and detention ponds and surface preparation shall be shown. The plan shall show the entire development. Details of erosion control devices can be shown on this sheet.

1.0133 - PROFILE SHEET.

Profiles for construction plans shall be the same horizontal scale as the plan sheet. Where profiles are drawn on the same sheet as the plan view, the profile shall be immediately below the plan view. Stationing shall be continuously upgrade from left to right with lower stations to the left. The following minimum information shall be shown:

- a. For sewers and storm drains, show locations of manholes, catch basins, and clean outs with each numbered and stationed as indicated in Section 1.0132(d).
- b. Existing profile at centerline of proposed utility or street.
- c. Proposed profile grade, as appropriate, for all sewers, storm drains and water lines giving pipe size, length between structures, slope, backfill type, surface restoration type, and pipe materials, sewer inverts, rim elevations, etc.
- d. Existing underground utility that crosses the alignment of the proposed facility.
- e. Beginning of all vertical curves, points of vertical intersection, end of vertical curve, low point of sag curve and length of vertical curve. Profiles of existing centerline grade shall extend a minimum of 250 feet beyond the end of the improvement.
- f. Clearly show all potential utility conflicts with appropriate pipes, conduits, vaults, etc. that affect proposed design.

SPECIAL NOTE: The City of Molalla as-builts are only to be used as an aid to the engineer. When a potential conflict may occur, the engineer shall field locate, or cause to be located, and verify the alignment, depth, and inverts of all existing facilities shown on the plans that will be crossed by the proposed facility.

1.0134 - DETAIL SHEETS

Detailed drawings shall be included with all construction plans where City of Molalla Standard drawings do not exist. If a standard drawing must be modified to fit existing or unique conditions, the modified drawing shall be shown on the plans. When appropriate, due to required detail complexity, a separate detail sheet shall be drawn. When City standard drawing appurtenances or construction installations are to be used, a reference to the specific Standard Drawing number shall be made on the title sheet.

1.0140 - SUPPORTING INFORMATION

The engineer shall submit sufficient supporting information to justify the proposed design. Such information shall include, but not be limited to, the following:

Design calculations.

Hydrology and hydraulic calculations with basin maps.

Alternate materials specifications including manufacturers' design application recommendations.

Plan support information to include as appropriate:

1. Soils engineering report
2. Hydrology report
3. Engineering geology report

1.0141 - UTILITY PLAN

When designing sanitary or storm sewer facilities, a utility plan shall be submitted with the construction plans when required by the Public Works Director. This plan shall be used to identify and analyze the extension of the proposed facilities. The topographic plan shall show all upstream and tributary areas within no less than 200 feet of the proposed development.

The plan shall include existing contours at one (1) foot intervals, or as approved by the City. Include location of existing structures and public and private utilities.

1.0150 - PLAN SUBMITTAL

Construction plans for all privately financed public works facility improvements shall be submitted to the City. The Public Works Director will coordinate the plan review and approval of all construction plans which will include review for compliance with all Molalla Design Standard, utility master plans, City Code and Ordinances.

All plan submittals shall include information required in Sections: 1.0140 and 1.0141 of these Design Standards along with all other information requested by the Public Works Director. This information shall include, but is not limited to, construction cost estimates, easement documents, right-of-way dedications, and executed agreements. All submittals will be reviewed for completeness and the engineer notified if required information is missing. Submittals should be made in a timely manner as lack of information to the City may impede the review process.

1.0160 - AS-BUILT PLAN REQUIREMENTS

For all public works facility improvements, the engineer shall submit certified as-built drawings for all plans which were approved for construction. As-built drawings shall meet the requirements of Sections 1.0100, 1.0130 and 1.0160 - 1.0164 of these Design Standards and shall be of archival quality. At a minimum, the drawings shall be 4 mil Mylar with silver halide emulsion. Original inked Mylars may also be submitted in lieu of photographic Mylars on Mylar sheets. In addition one (1) set of blue line as-builts shall be submitted.

The engineer shall submit, along with the as-built drawings, a statement certifying that all work for which plans were approved has been completed in accordance with the Molalla Public Works Design Standards and Standard Specifications and design documents.

The words "As-Built Drawing" shall appear as the last entry in the revision block along with the month, day and year the as-built drawing was prepared.

NOTE: Actual location and depth from finish grade of any other utilities encountered during construction shall be noted on as-built plans.

1.0161 - STREET

The following minimum information shall be noted on the street as-builts

- a. Change in horizontal alignment, curve data and stationing of primary control points (e.g., PC, PI, PT, PRC).
- b. Vertical curve or grade changes; change in location of low point in sag vertical curve.
- c. Change to approved thickness for street structural section components. Show station limits where changes in structural section have occurred.
- d. Change to driveway locations or widths.
- e. Other change(s) altering the approved plans, including but not limited to; curbs, sidewalks, wheelchair ramps and lighting.

1.0162 - STORM DRAINS

The following minimum information shall be noted on storm drain as-built drawings:

- a. Station of wye or tee into main line. Tie each end of branch line to nearest property corner a right-of-way line, and distance back from the face of curb.
- b. Show alignment changes, grade changes and changes in construction materials. If changed alignment results in station changes, a station equation shall be shown as appropriate at a manhole.
- c. Other change(s) altering the approved plans, including but not limited to; catch basin location, manhole location, pipe size, dry well location, etc.

1.0163 - SANITARY SEWER

The following minimum information shall be noted on sanitary sewer as-built drawings:

- a. Station of wye or tee into main line. Tie each end of service lateral to nearest property corner at right-of-way line, and distance back from the face of curb.
- b. Depth at the end of service lateral measured from existing ground to invert of pipe. When required by the Public Works Director, invert elevations shall be noted.
- c. Length of service lateral measured from centerline of sewer main to end of pipe.
- d. Show alignment changes, grade changes, pipe size changes and changes in construction materials. If changed alignment results in station changes, a station equation shall be shown as appropriate at a manhole.
- e. Other change altering the approved plans.
- f. Provide complete test results to the Public Works Director.
- g. Type of pipe, backfill material and location.

1.0164 - WATER MAIN

The following minimum information shall be noted on water main as-built drawings:

- a. Station and/or property line/corner to valves (not at standard location), all fittings, blow-offs and dead-ended lines.

- b. All changes from standard 30-inch depth cover. Limits shall be shown on all plans with annotated reason for change. Actual pipe elevation (top of pipe) will be taken at each fitting.
- c. Show alignment changes, grade changes, pipe size changes and changes in construction materials, if changed alignment results in station changes. A station equation shall be shown as appropriate at a valve.
- d. Provide manufacturer of all valves; identify types of fittings (i.e., MJ X MJ, FLG x MJ, etc.); provide information in the form of an inventory list on construction drawings.
- e. Other change altering the approved plans.
- f. Provide complete test results to the Public Works Director.
- g. Provide photographs of all installed valves, thrust blocks, and fittings in place before backfill.

**CITY OF MOLALLA
PUBLIC WORKS
DESIGN STANDARDS**

SECTIONS: 2.0000 - EXCAVATION AND GRADING

2.0010 - PURPOSE

The purpose of this section is to safeguard life, limb, property and the public welfare by regulating grading on private property.

2.0020 - SCOPE

This section sets forth rules and regulations to control excavation, grading and earthwork construction, including fills and embankments; establishes the administrative procedure for issuance of permits; and provides for approval of plans and inspection of grading construction.

The standards listed below are guideline standards and as such are not adopted as part of this code.

1. Testing
 - A. ASTM D 1557, Moisture-density Relations of Soils and Soil Aggregate Mixtures
 - B. ASTM D 1556, In Place Density of Soils by the Sand-Cone Method
 - C. ASTM D 2167, In Place Density of Soils by the Rubber-Balloon Method
 - D. ASTM D 2937, In Place Density of Soils by the Drive-Cylinder Method
 - E. ASTM D 2922 and D 3017, In Place Moisture Content and Density of Soils by Nuclear Methods.

2.0030 - PERMITS REQUIRED

- a. **Permits Required.** Except as specified in Subsection (b) of this section, no person shall do any grading without first having obtained a grading permit from the City.
- b. **Exempted Work.** A grading permit is not required for the following:
 1. When approved by the Public Works Director, grading in an isolated, self-contained area if there is no danger to private or public property.
 2. An excavation below finished grade for basements and footings of a building, retaining wall or other structure authorized by a valid building permit. This shall not exempt any fill made with the material from such excavation or exempt any excavation having an unsupported height greater than 5 feet after the completion of such structure.
 3. Cemetery graves.
 4. Refuse disposal sites controlled by other regulations.
 5. Excavations for wells or tunnels or utilities.
 6. Mining, quarrying, excavating, processing, stockpiling of rock, sand, gravel, aggregate or clay where established and provided for by law, provided such operations do not affect the lateral support or increase the stresses in or pressure upon any adjacent or contiguous property.

7. Exploratory excavations under the direction of soil engineers or engineering geologists.
8. An excavation which (1) is less than 2 feet in depth, or (2) which does not create a cut slope greater than 5 feet in height and steeper than 2 horizontal to 1 vertical and is less than 50 cubic yards.
9. A fill less than 1 foot in depth and placed on natural terrain with a slope flatter than 5 horizontal to 1 vertical, or less than 3 feet in depth, not intended to support structures, which does not exceed 50 cubic yards on any one lot and does not obstruct a drainage course.

Exemption from the permit requirements of this chapter shall not be deemed to grant authorization for any work to be done in any manner in violation of the provisions of this chapter or any other laws or ordinances of this jurisdiction, or of county, state or federal jurisdictions..

2.0040 - HAZARDS

Whenever the Public Works Director determines that any existing excavation or embankment or fill on private property has become a hazard to life and limb, or endangers property, or adversely affects the safety, use or stability of a public way or drainage channel, the owner of the property upon which the excavation or fill is located, or other person or agent in control of said property, upon receipt of notice in writing from the Public Works Director, shall within the period specified therein repair or eliminate such excavation or embankment so as to eliminate the hazard and be in conformance with the requirements of this code.

2.0050 - DEFINITIONS

For the purpose of this section the definitions listed thereunder shall be construed as specified in this section.

APPROVAL - shall mean the proposed work or completed work conforms to this chapter in the opinion of the Public Works Director.

AS-GRADED - is the extent of the surface conditions on completion of grading.

BEDROCK - is in-place solid rock.

BENCH - is a relatively level step excavated into earth material on which fill is to be place.

BORROW - is earth material acquired from an off-site location for use in grading on a site.

CIVIL ENGINEER - is a professional engineer registered in the state to practice in the field of civil works.

COMPACTION - is the densification of a fill by mechanical means.

EARTH MATERIAL - is any rock, natural soil or fill or any combination thereof.

ENGINEERING GEOLOGIST - is a geologist experienced and knowledgeable in engineering geology.

ENGINEERING GEOLOGY - is the application of geologic knowledge and principles in the investigation and evaluation of naturally occurring rock and soil for use in the design of civil works.

EROSION - is the wearing away of the ground surface as result of the movement of wind, water or ice

EXCAVATION - is the mechanical removal of earth material.

EXISTING - grade is the grade prior to grading.

FINISH - grade is the final grade of the site which conforms to the approved plan.

FILL - is the deposit of earth material placed by artificial means.

GEOTECHNICAL ENGINEER - See "soils engineer."

GRADE - is the vertical location of the ground surface.

GRADING - is any excavating or filling or combination thereof.

KEY - is a designed compacted fill placed in a trench excavated in earth material beneath the toe of a proposed fill slope.

PROFESSIONAL INSPECTION - is the inspection required by this code to be performed by the civil engineer, soils engineer or engineering geologist. Such inspections include that performed by persons supervised by such engineers or geologists and shall be sufficient to form an opinion relating to the conduct of the work.

ROUGH - grade is the stage at which the grade approximately conforms to the approved plan.

SITE - is any lot or parcel of land or contiguous combination thereof, under the same ownership, where grading is performed or permitted.

SLOPE - is an inclined ground surface the inclination of which is expressed as a ratio of horizontal distance to vertical distance.

SOIL - is naturally occurring superficial deposits overlying bedrock.

SOILS ENGINEER (GEOTECHNICAL ENGINEER) - is an engineer experienced and knowledgeable in the practice of soils engineering (GEOTECHNICAL) engineering.

SOILS ENGINEERING (GEOTECHNICAL ENGINEERING) - is the application of the principles of soils mechanics in the investigation, evaluation and design of civil works involving the use of earth materials and the inspection or testing of the construction thereof.

TERRACE - is a relatively level step constructed in the face of a graded slope surface for drainage and maintenance purposes.

2.0060 - GRADING PERMIT REQUIREMENTS

- a. **Permits Required.** Except as exempted in Section 2.0030(b) of this code, no person shall do any grading without first obtaining a grading permit from the Public Works Director. A separate permit shall be obtained for each site, and may cover both excavations and fills.
- b. **Application.** The provisions of Section 2.0030(a) are applicable to grading and in addition the application shall state the estimated quantities of work involved.
- c. **Grading Designation.** Grading in excess of 5,000 cubic yards or grading which involves fill to support structures, shall be performed in accordance with the approved grading plan prepared by a civil engineer, and shall be designated as "engineered grading." Grading involving less than 5,000 cubic yards shall be designated "regular grading" unless the permittee chooses to have the grading performed as engineered grading, or the Public Works Director determines that special conditions or unusual hazards exist, in which case grading shall conform to the requirements for engineered grading.
- d. **Engineered Grading Requirements.** Application for a grading permit shall be accompanied by two sets of plans and specifications, and supporting data consisting of a soils engineering report and engineering geology report. The plans and specifications shall be prepared and signed by an individual licensed by the state to prepare such plans or specifications when required by the building official.

Specifications shall contain information covering construction and material requirements.

Plans shall be prepared in accordance with Section 1.0000 of this of the document and shall be of sufficient clarity to indicate the nature and extent of the work proposed and shown in detail that they will conform to the provisions of this code and all relevant laws, ordinances, rules and regulations. The first sheet of each set of plans shall give location of the work, the names and address of the owner and the person by whom they were prepared.

The plans shall include the following information:

1. General vicinity of the proposed site.
 2. Property limits and accurate contours of existing ground and details of terrain and area drainage.
 3. Limiting dimensions, elevations or finish contours to be achieved by the grading, and proposed drainage channels and related construction.
 4. Detailed plans of all surface and subsurface drainage devices, wall, cribbing, dams and other protective devices to be constructed with, or as a part of, the proposed work together with a map showing the drainage area and the estimated runoff of the area served by any drain.
 5. Locations of any building or structures on the property where the work is to be performed and the location of any buildings or structures on land of adjacent owners which are within 15 feet of the property or which may be affected by the proposed grading operations.
 6. Recommendations included in the soils engineering report and the engineering geology report shall be incorporated in the grading plans or specifications. When approved by the Public Works Director, specific recommendations contained in the soils engineering report and the engineering geology report, which are applicable to grading, may be included by reference.
 7. The dates of the soils engineering and engineering geology reports together with the names, addresses and phone numbers of the firms or individuals who prepared the reports.
- e. **Soils Engineering Report.** The soils engineering report required by Subsection (d) shall include data regarding the water table, the nature, distribution and strength of existing soils, conclusions and recommendations for grading procedures and design criteria for corrective measures, including buttress fills, when necessary, and opinion on adequacy for the intended use of sites to be developed by the proposed grading as affected by soils engineering factors, including the stability of slopes.
- f. **Engineering Geology Report.** The engineering geology report required by Subsection (d) shall include an adequate description of the geology of the site, conclusions and recommendations regarding the effect of geologic conditions on the proposed development, and opinion on the adequacy for the intended use of sites to be developed by the proposed grading, as affected by geologic factors.
- g. **Regular Grading Requirements.** Each application for a grading permit shall be accompanied by a plan in sufficient clarity to indicate the nature and extent of the work. The plans shall give the location of the work, the names of the owner and the name of the person who prepared the plan. The plan shall include the following information:
1. General vicinity of the proposed site.
 2. Limiting dimensions and depth of cut and fill.
 3. Location of any buildings or structures where work is to be performed, and the location of any buildings or structures within 15 feet of the proposed grading.

4. An engineering soils and geology report may be required by the City depending upon site conditions such as steep slopes, evidence of slippage or slides, high ground water, location of improvements, geologic conditions, etc.
- h. **Issuance.** The provisions of Section 7.0000 are applicable to grading permits. The Public Works Director may require that grading operations and project designs be modified if delays occur which incur weather-generated problems not considered at the time the permit was issued.

The Public Works Director may require professional inspection and testing by the soils engineer. When the Public Works Director has caused to believe that geologic factors may be involved, the grading will be required to conform to engineered grading.

2.0080 - BONDS

The Public Works Director may require bonds in such form and amounts as may be deemed necessary to assure that the work, if not completed in accordance with the approved plans and specifications, will be corrected to eliminate hazardous conditions.

In lieu of a surety bond the applicant may file a cash bond or instrument of credit with the City in an amount equal to that which would be required in the surety bond.

2.0090 - CUTS

- a. **General.** Unless otherwise recommended in the approved soils engineering or engineering geology report, cuts shall conform to the provisions of this section..

In the absence of an approved soils engineering report, these provisions may be waived for minor cuts not intended to support structures.

- b. **Slope.** The slope of cut surfaces shall be no steeper than is safe for the intended use and shall be no steeper than 2 horizontal to 1 vertical unless the permittee furnishes a soils engineering or a engineering geology report, or both, stating that the site has been investigated and giving an opinion that a cut at a steeper slope will be stable and not create a hazard to public or private property.

2.0100 - FILLS

- a. **General.** Unless otherwise recommended in the approved soils engineering report, fills shall conform to the provisions of this section.

In the absence of an approved soils engineering report, these provisions may be waived for minor fills not intended to support structures.

- b. **Preparation of Ground.** Fill slopes shall not be constructed on natural slopes steeper than 2:1. The ground surface shall be prepared to receive fill by removing vegetation, noncomplying fill, topsoil and other unsuitable material scarifying to provide a bond with the new fill and, where slopes are steeper than 5:1 and the height is greater than five (5) feet, by benching into sound bedrock or other competent material as determined by the soils engineer. The bench under the toe of a fill on a slope steeper than 5:1 shall be at least ten (10) feet wide. The area beyond the toe of fill shall be sloped for sheet overflow or a paved drain shall be provided. When fill is to be placed over a cut, the bench under the toe of fill shall be at least ten (10) feet wide but the cut shall be made before placing the fill and acceptance by the soils engineer or engineering geologist or both as a suitable foundation for fill.
- c. **Fill Material.** Organic material shall not be permitted in fills. Except as permitted by the Public Works Director, no rock or similar irreducible material with a maximum dimension greater than twelve (12) inches shall be buried or placed in fills.

Exception: The Public Works Director may permit placement of larger rock when the soils engineer properly devises a method of placement, and continuously inspects its placement and approves the fill stability. The following conditions shall also apply:

1. Prior to issuance of the grading permit, potential rock disposal areas shall be delineated on the grading plan.
 2. Rock sizes greater than twelve (12) inches in maximum dimension shall be ten (10) feet or more below grade, measured vertically.
 3. Rocks shall be placed so as to assure filling of all voids with well-graded soil.
- d. **Compaction.** All fills shall be compacted to a minimum of 90 percent of maximum density per ASTM D-1557, unless Geotech report suggest a denser compaction.
- e. **Slope.** The slope of fill surfaces shall be no steeper than is safe for the intended use. Fill slopes shall be no steeper than 2 horizontal to 1 vertical.

2.0110 - SETBACKS

- a. **General.** Cut and fill slopes shall be set back from site boundaries in accordance with this section. Setback dimensions shall be horizontal distances measured perpendicular to the site boundary. Setback dimensions shall be as shown in Figure No. 2-1.
- b. **Top of Cut Slope.** The top of cut slope shall not be made nearer to a site boundary line than one fifth of the vertical height of cut with a minimum of 2 feet and a maximum of 20 feet. Where a fill slope is to be located near the site boundary and the adjacent off-site property is developed, special precautions shall be incorporated in the work as the Public Works Director deems necessary to protect the adjoining property from damage as a result of such grading. These precautions may include but are not limited to:
1. Additional setbacks.
 2. Provision for retaining or slough walls.
 3. Mechanical or chemical treatment of the fill slope surface to minimize erosion.
 4. Provisions for the control of surface waters.
- d. **Modification of Slope Location.** The Public Works Director may approve alternate setbacks. The Public Works Director may require an investigation and recommendation by a qualified engineer or engineering geologist to demonstrate that the intent of this section has been satisfied.

2.0120 - DRAINAGE AND TERRACING

- a. **General.** Unless otherwise indicated on the approved grading plan, drainage facilities and terracing shall conform to the provisions of this section for cut or fill slopes steeper than 3 horizontal to 1 vertical.
- b. **Terrace.** Terraces at least 6 feet in width shall be established at not more than 30-foot vertical intervals on all cut or fill slopes to control surface drainage and debris except that where only one terrace is required, it shall be at mid-height. For cut or fill slopes greater than 60 feet and up to 120 feet in vertical height, one terrace at approximately mid-height shall be 12 feet in width. Terrace widths and spacing for cut and fill slopes greater than 120 feet in height shall be designed by the civil engineer and approved by the Public Works Director. Suitable access shall be provided to permit proper cleaning and maintenance.

Swales or ditches on terraces shall have a minimum gradient of 5 percent and must be paved with reinforced concrete not less than 3 inches in thickness or an approved equal paving. They shall have a minimum depth at the deepest point of 1 foot and a minimum paved width of 5 feet.

A single run of swale or ditch shall not collect runoff from a tributary area exceeding 13,500 square feet (projected) without discharging into a down drain.

- c. **Subsurface Drainage.** Cut and fill slopes shall be provided with subsurface drainage as necessary for stability.
- d. **Disposal.** All drainage facilities shall be designed to carry waters to the nearest practicable drainage way approved by the Public Works Director or other appropriate jurisdiction as a safe place to deposit such water, erosion of ground in the area of discharge shall be prevented by installation of non-corrosive down drains or other devices.

Building pads shall have a drainage gradient of 2 percent toward approved drainage facilities, unless waived by the Public Works Director.

Exception: The gradient from the building pad may be 1 percent if all of the following conditions exist throughout the permit area:

- 1. No proposed fills are greater than 10 feet in maximum depth.
 - 2. No proposed finish cut or fill slope faces have a vertical height in excess of 10 feet.
 - 3. No existing slope faces, which have a slope face steeper than 10 horizontal to 1 vertical, have a vertical height in excess of 10 feet.
- e. **Interceptor Drains.** Paved interceptor drains shall be installed along the top of all cut slopes where the tributary drainage area above slopes toward the cut and has a drainage path greater than 40 feet measured horizontally. Interceptor drains shall be paved with a minimum of 3 inches of concrete or gunite and reinforced. They shall have a minimum depth of 12 inches and minimum paved width of 30 inches measured horizontally across the drain. The slope of drain shall be approved by the city official.

2.0130 - EROSION CONTROL

- a. **Slopes** The faces of cut and fill slopes shall be prepared and maintained to control against erosion. This control may consist of effective planting, matting or covering. The protection for the slopes shall be installed as soon as practicable and prior to calling for final approval. Where cut slopes are not subject to erosion due to the erosion-resistant character of the materials, such protection may be omitted.
- b. **Other Devices.** Where necessary, check dams, cribbing, rip-rap or other devices or methods shall be employed to control erosion and provide safety.
- c. **Construction.** Temporary erosion control facilities shall be used to protect against erosion during construction. See Section 3.0050 for requirements.

2.0140 - GRADING INSPECTION

- a. **General.** Grading operations for which a permit is required shall be subject to inspection by the city. Professional inspection of grading operations shall be provided by the civil engineer, soil engineer and the engineering geologist retained to provide such services in accordance with Section 2.0140 (e) for engineered grading and as required by the city for regular grading.
- b. **Civil Engineer.** The civil engineer shall provide professional inspection within such engineer's area of technical specialty, which shall consist of observation and review as to the establishment of line, grade and surface drainage of the development area. If revised plans are required during the course of the work they shall be prepared by the civil engineer.
- c. **Soils Engineer.** The soils engineer shall provide professional inspection within such engineer's area of technical specialty, which shall include observation during grading and testing for required compaction. The soils engineer shall provide sufficient observation during the preparation of the natural ground and placement and compaction of the fill to verify that such work is being performed in accordance with the conditions of the approved plan and the

appropriate requirements of this chapter. Revised recommendations relating to conditions differing from the approved soils engineering and engineering geology reports shall be submitted to the permittee, the city inspector and the civil engineer.

- d. **Engineering Geologist.** The engineering geologist shall provide professional inspection within such engineer's area of technical specialty, which shall include professional inspection of the bedrock excavation to determine if conditions encountered are in conformance with the approved report, revised recommendations relating to conditions differing from the approved engineering geology report shall be submitted to the soils engineer.
- e. **Permittee.** The permittee shall be responsible for the work to be performed in accordance with the approved plans and specifications and in conformance with the provisions of this code, and the permittee shall engage consultants, if required, to provide professional inspections on a timely basis. The permittee shall act as a coordinator between the consultants, the contractor and the city inspector. In the event of changed conditions, the permittee shall be responsible for informing the city inspector of such change and shall provide revised plans for approval.
- f. **City inspector.** The city inspector shall inspect the project at the various stages of work requiring approval to determine that adequate control is being exercised by the professional consultants.
- g. **Notification of Noncompliance.** If, in the course of fulfilling their respective duties under this chapter, the civil engineer, the soils engineer or the engineering geologist finds that the work is not being done in conformance with this chapter or the approved grading plans, the discrepancies shall be reported immediately in writing to the permittee and to the city inspector.
- h. **Transfer of Responsibility.** If the civil engineer, the soils engineer, or the engineering geologist of record is changed during grading, the work shall be stopped until the replacement has agreed in writing to accept their responsibility within the area of technical competence for approval upon completion of the work.

It shall be the duty of the permittee to notify the city inspector in writing of such change prior to the recommencement of such grading.

2.0150 - COMPLETION OF WORK

- a. **Final Reports.** Upon completion of the rough grading work and at the final completion of the work, the following reports and drawings and supplements thereto are required for engineered grading or when professional inspection is performed for regular grading, as applicable.
 - 1. An as-built grading plan prepared by the civil engineer retained to provide such service in accordance with Section 7014 (e) showing original ground surface elevations, as-graded ground surface elevations, lot drainage patterns, and the locations and elevations of surface drainage facilities and of the outlets of subsurface drains. As-constructed locations, elevations and details of subsurface drains shall be shown as reported by the soils engineer.

Civil engineers shall submit a statement that to the best of their knowledge the work within their area of responsibility was done in accordance with the final approved grading plan.
 - 2. A report prepared by the soils engineer retained to provide such services in accordance with Section 7014 (c), including locations and elevations of field density test, summaries of field and laboratory test, other substantiating data, and comments on any changes made during grading and their effect on the recommendations made in the approved soils engineering investigation report. Soils engineers shall submit a statement that, to the best of their knowledge, the work within their area of responsibilities is in accordance with the approved soils engineering report and applicable provisions of this chapter.
 - 3. A report prepared by the engineering geologist retained to provide such services in accordance with Section 7014 (e), including a final description of the geology of the site and any new information disclosed during the grading and the effect of same on recommendations incorporated in the approved grading plan. Engineering geologists

shall submit a statement that, to the best of their knowledge, the work within their area or responsibility is in accordance with the approved engineering geologist report and applicable provisions of this chapter.

4. The grading contractor shall submit in a form prescribed by the city inspector in a statement of conformance to said as-built plan and the specifications.
- b. **Notification of Completion.** The permittee shall notify the city inspector when the grading operation is ready for final inspection. Final approval shall not be given until all work, including installation of all drainage facilities and their protective devices, and all erosion-control measures have been completed in accordance with the approved grading plan, and the required reports have been submitted.

CITY OF MOLALLA PUBLIC WORKS DESIGN STANDARDS

3.0000 - STORM DRAINAGE

3.0010 - GENERAL DESIGN REQUIREMENTS

Performance Standards - Storm drainage design within a development area must include provisions to adequately control runoff from all public and private streets and the roof, footing, and area drains of residential, multi-family, commercial, or industrial buildings. The design must ensure future extension of the drainage system to the entire drainage basin in conformance with these Design Standards. These provisions include:

- a. Surface or subsurface drainage, caused or affected by the changing of the natural grade of the existing ground or removal of natural ground cover or placement of impervious surfaces, shall not be allowed to flow over adjacent public or private property in a volume or location materially different from that which existed before development occurred, but shall be collected and conveyed in an approved manner to an approved point of disposal.
- b. Surface water entering the subject property shall be received at the naturally occurring locations and surface water exiting the subject property shall be discharged at the natural locations with adequate energy dissipaters within the subject property to minimize downstream damage and with no diversion at any of these points.
- c. The approved point of disposal for all storm water may be a storm drain, dry wells, existing open channel, creek, detention, or retention pond approved by the Public Works Director. Acceptance of suggested systems will depend upon the prevailing site conditions, capacity of existing downstream facilities, and feasibility of the alternate design.
- d. When private property must be crossed in order to reach an approved point of disposal, it shall be the developer's responsibility to acquire a recorded drainage easement (of dimensions in accordance with those included in Section 3.0024). The drainage facility installed must be a closed conduit system. Temporary drainage ditch facilities, when approved, must be engineered to contain the storm water without causing erosion or other adverse effects to the private property.
- e. The design peak discharge from the subject property may not be increased from conditions existing prior to the proposed development except where it can be satisfactorily demonstrated by the applicant that there is no adverse impact.
- f. Retention/detention facilities will be required where necessary to maintain surface water discharge rates at or below the existing design storm peak discharge except where it can be demonstrated by the applicant that no adverse impact will result from not providing said facilities.
- g. Minimum width of an access easement from an existing public road to a drainage facility shall be fifteen (15) feet.
- h. Drainage from roofs, footings, and downspouts may drain directly to a street through the curb under the following circumstances:
 1. The building pad ground elevation is at least two (2) feet above the existing street curb, and
 2. The existing street is adequately crowned to avoid sheet flow across the street. This requirement will be waived if curb and gutter is existing or installed.
- i. Vegetation shall be established on areas disturbed by/or on areas of construction as necessary to minimize erosion, in accordance with Section 3.0050 of these standards.

All storm drain system designs shall make adequate provisions for collecting all storm water runoff. The system shall accommodate all runoff from upstream tributary areas whether or not such areas are within the proposed development. The amount of runoff to be accommodated shall be based upon ultimate development of all upstream tributary areas.

Where storm drains are constructed on slopes greater than 20%, in areas designated as hazardous or where there are site conditions that may cause damage to improvements, slippage or slides or determined by the Public Works Director, a soils and/or geologic report may be required.

For erosion control requirements refer to Section 2.0130.

Where the finished graded surface has a greater than 20% slope, or as required, soil stabilization fabric shall be placed over the entire disturbed area.

Proposed storm drain systems shall not discharge flows into inadequate downstream systems unless approved by the Public Works Director.

Public storm lines shall be located within the public right-of-way as directed by the Public Works Director, per Section 3.0021. These lines are placed in the public right-of-way for ease of maintenance access, control of the facility, operation of the facility, and to provide required replacement and/or repair.

Floodplain information, delineating the 100-year floodplain limits, shall be shown where it occurs within the development. Floodplain limits shall be based on maps prepared by the U.S. Army Corps of Engineers and the Federal Emergency Management Agency (F.E.M.A.) Where better information is available, it shall be used by the Design Engineer.

Standard drawings relevant to this section may be found in the most current specifications and edition of the APWA Standard Specifications for Public Works Construction, Oregon Chapter.

3.0011 - SITE DRAINAGE PLANS

Existing Drainage Plan - Provide a topographical contour map defining existing conditions to include the following minimum information:

- a. Two-foot (2') contour intervals, slopes over 10% may use 5-foot (5') intervals extend Contours a minimum of 100 feet beyond property.
- b. All structures, buildings, parking lots and utilities on the property.
- c. Isolation of all existing drainage facilities and water courses, including wetlands and flood plain areas.

Locations of all subsurface water outlets (e.g., - springs.) Show arrows to indicate direction of flow for all drainage information.

Proposed Drainage Plan - Show proposed site grading and drainage facilities on a topographical contour map. Unless the detail for proposed improvements will obscure the conditions shown on the existing drainage plan, proposed site grading and drainage may be shown on the existing drainage plan. The following minimum information shall also be shown.

- a. Finished contours of the property after development shall be at two-foot (2') contour intervals, slopes over 10% may use 5-foot (5') intervals, extend contours a minimum of 100 feet beyond property.
- b. Percent grade, for graded slopes, elevations, dimensions and locations for all graded slopes.
- c. Cut/fill areas' structural fill placement areas erosion/sedimentation control methods reseeding areas.
- d. All proposed drainage facilities - public and private systems; drainage ditches, culverts.

Drainage Calculations - Furnish such supporting information as required per Section: 1.0140 of these Design Standards.

Detention Requirements - All proposed development will be required to use adequate drainage management practices. Developments located within a master planned drainage basin will follow the recommendations adopted to that plan. Developments not located within master planned drainage basins will minimize the rate and amount of runoff to receiving systems and streams.

3.0012 - PIPE MATERIALS AND SIZE

Public storm drains may be constructed of the following materials: Concrete, Ductile Iron, PVC, HDPE.

When pipe has less than minimum cover as defined in Section 3.0023 the pipe material shall be ductile iron.

Public and private storm drain pipe shall meet the appropriate sections of the Uniform Plumbing Code.

All public storm drain lateral lines to catch basins and other inlet structures shall be a minimum of ten inches (10") in diameter. All public storm drain main lines shall be a minimum of twelve inches (12") in diameter.

3.0013 - MINIMUM DESIGN CRITERIA

Storm Frequency - All public storm drain systems shall be designed for the design storm recurrence interval in the following table:

DRAINAGE SYSTEM DESIGN CAPACITY

Drainage System Element	Design Storm Recurrence Interval Years
Minor:	25
Streets, curbs, gutters, inlets catch basin and connector drains	
Major:	
Laterals (collectors) < 100 tributary acres	25
Trunk > 100 tributary acres	50*
Arterial Streets and the Drainage System in or under Arterial Streets	50*
Watercourses: without designated floodplain	50
with designated floodplain	100
Bridges	100
Detention Facilities: Storage volume (on site)	25
Storage volume	100
Discharge rate	Function of down-stream capacity

* SURCHARGING contained within pipe system will be allowed.

Time of Concentration - Overland flow of runoff to the initial catchment point into the storm drain system shall be a minimum of ten (10) minutes.

Velocity and Slope - All storm drains shall be on a grade which produces a mean velocity, when flowing full, of at least three feet (3') per second.

Manning Equations - When calculating minimum pipe slopes and velocities, the design engineer shall use the Manning pipe friction formula.

Pipe Coefficient - The storm drain pipe roughness coefficient to be used in the Manning formula shall be not less than 0.013.

Storm Water Flows - For areas under 100 acres, the "Rational" formula shall be used. For areas over 100 acres, a hydrographic based formula shall be used. A hydrograph method shall be used to size detention facilities. Detention facility outfall control structures shall be sized to consider capacities of downstream facilities.

3.0020 - ALIGNMENT AND COVER

3.0021 - RIGHT-OF-WAY LOCATION

Storm drain lines shall generally be located five (5) feet (south or east) from right-of-way to centerline. All changes in direction of pipe shall be made at an approved structure, except as provided in Section: 3.0022.

3.0022 - CURVATURE

Storm drain lines shall not be curved between structures. If unusual circumstances are present, as determined by the Public Works Director, small diameter storm drains may be curved. Such curves shall conform to the street curvature.

3.0023 - MINIMUM COVER

All storm drains shall be laid at a depth sufficient to protect against damage by traffic and to drain building footings where practical. Sufficient depth shall mean the minimum cover from the top of the pipe to finish grade at the storm drain alignment.

Minimum cover shall be thirty inches (30") above the top of the pipe in paved areas and thirty-six inches (36") at all other locations. Less than minimum cover shall be allowed only, if unusual circumstances are present, as determined by the Public Works Director.

The design engineer must show that sufficient depth is provided at the boundary of the development to properly drain the remainder of the upstream basin area tributary to the site.

3.0024 - EASEMENTS

- a. When it is necessary to locate storm drains in easements, the storm drain shall be centered in the easement. All storm drain easements shall be exclusive and shall not be used for any purpose which would interfere with the unrestricted use of the storm drain line. Exceptions to this requirement will be reviewed on a case by case basis, (e.g., a utility corridor in a new subdivision).
- b. Easements for storm drain lines thirty-six inches (36") or less in diameter shall have a minimum width of fifteen feet (15'). All pipe lines greater than thirty-six inches (36) in diameter, shall have a minimum width of twenty feet (20'). Larger widths may be required for special circumstances, such as excessively deep pipe or location of building to the easement.
- c. Open channels shall have easements sufficient in width to cover the 100-year Floodplain Line when a 100-year design storm is required or fifteen feet (15') from the waterway centerline or ten feet (10') from the top of the recognized bank, whichever is greater. A fifteen-foot (15') wide

access easement shall be provided on both sides of the channel for channel widths greater than fourteen feet (14') at the top of the recognized bank.

- d. Easement locations for public storm drains serving a PUD, apartment complex, or commercial/industrial development shall be in parking lots, private drives, or similar open areas which will permit unobstructed vehicle access for maintenance.
- e. Structures cannot be built over the easements, and trees and large bushes cannot be planted in the easement.
- f. All easements must be furnished to the City for review and approval prior to recording.

3.0025 - RELATION TO WATERCOURSES

Storm drain lines shall enter a creek or drainage channel at 90° or Less to the direction of flow. The outlet shall have a head wall and scour pad or rip rap to prevent erosion of the existing bank or channel bottom. The size of pipe or channel being entered will govern which protective measures are required. All protective measures must conform to the requirements of Section 3.0050 of these Design Standards.

3.0030 - STRUCTURE LOCATION

3.0031 - MANHOLES

Manholes shall be located at all changes in slope, alignment, pipe size, and at all pipe junctions with present or future storm drains. Manhole spacing shall not be greater than 400 feet.

Standard manholes are required when rim to crown of pipe elevations exceed four feet (4') at pipe junctions. Flat-top manholes shall be used when rim to crown of pipe elevations are less than four feet (4').

When the downstream pipe size increases, the crown of all upstream pipes shall not be lower than the crown of the larger downstream pipe.

3.0032 - CATCH BASINS

Catch basins shall be located in streets at the curb line to receive storm water runoff and convey it to the main storm drain.

Catch basins shall be located at the following locations but in no case be spaced further than 300 feet:

- a. At curb returns on the upstream side of an intersection.
- b. At the ends of all dead-end streets with a descending grade.
- c. At intermediate locations so that storm flows at the curb line do not exceed three feet (3') in width (measured from the curb face) or three inches (3") in depth (measured at the curb face,) whichever is less.
- d. At all low points.
- e. On street grades greater than 10 % the maximum spacing shall be 150 feet.
- f. On street grades less than 1% the maximum spacing shall be 150 feet.
- g. Catch basin inlets and grates shall be positioned to avoid conflict with wheelchair ramps.

Catch basins shall be capable of intercepting, completely, the design storm flows at the curb.

3.0033 - DRY WELLS

Where there are no natural or constructed drain ways, or an existing storm water system, dry wells can be used as a discharge point with the approval of the Public Works Director.

Dry well systems shall be constructed with two manholes. The collector pipes shall discharge into the first manhole, which shall be constructed as an oil-water separator and settling basin. Liquid will then flow to the second manhole, which shall be a perforated manhole. The second manhole shall extend down to river rock or to the natural water table.

3.0034 - ANCHOR BLOCKS

For storm drain pipes greater than four (4) inches in diameter, concrete anchor blocks shall be required if the slopes are greater than twenty (20) percent. Anchor blocks shall key into trench sides. Spacing for anchor blocks is as follows:

SPACING FOR ANCHOR BLOCK FOR ALL SIZE PIPE

SLOPE %	MINIMUM SPACING (FT)
0 - 19.99	NO ANCHOR REQUIRED
20 - 34.99	35
35 - 50.99	25
51 - OR MORE	15 OR SPECIAL DESIGN

3.0035 - WATER BARS

Where the finished graded surface has a slope greater than or equal to 3 units horizontal to 1 unit vertical or as required, water bars shall be installed. The water bars shall be sloped slightly to drain runoff water away from the pipe line alignment. Water bars shall have a maximum spacing of forty (40) feet.

3.0040 - STORM DETENTION

3.0041 - DEVELOPMENT NOT REQUIRING DETENTION

In general, developments meeting the following criteria will not be required to provide detention:

- a. Land divisions of less than four lots.
- b. Multi-family developments of less than four units.
- c. Commercial and industrial development where the construction of a new facility or expansion of an existing facility will not increase the impervious area by more than 5,000 square feet.

3.0043 - DETENTION VOLUME

When detention is required, the volume to be detained shall be based on the following:

The rate of runoff from a developed site during a 25-year recurrence interval storm shall not exceed the pre-development rate of runoff released based on a 10-year recurrence interval storm.

3.0044 - EMERGENCY OVERFLOW

The Design Engineer shall assess the impacts of system failure for on-site detention. Overflows may occur due to rainfall intensity which exceeds the design storm, debris blockage of storm drain system, or some other reason.

If a system overflows, it shall not cause inundation of neighboring properties. Potential overflow routes shall be protected from erosion by adequate means.

3.0045 - DETENTION FACILITIES

Detention volume storage methods in order of preference are the following:

- a. Surface storage
- b. Underground storage

Detention Facilities - Detention facilities which are intended to be transferred to the City shall be designed with good access for maintenance and shall have access right-of-way deeded to the City. A maintenance plan for the detention facility shall be submitted.

3.0050 - EROSION CONTROL

Developments shall provide erosion control methods to limit the removal of soil materials by storm runoff during the construction phases of a project.

3.0051 - EROSION CONTROL - APPLICATION

1. For subdivision plats temporary erosion control measures also shall be utilized by the applicant during installation of plat improvements and by subsequent builders during construction of dwellings and other lot improvements.
2. Prior to the initial clearing and grading of any land development, provisions shall be made for the interception of all potential silt-laden runoff that could result from said clearing and grading. Said interception shall preclude any silt-laden runoff from discharging from the proposed land development to downstream properties unless previously approved by the Public Works Director. Said interception shall cause all silt-laden runoff to be conveyed by open ditch or other means to whatever temporary facility is necessary to remove silt prior to discharge to downstream properties.
3. Prior to initial clearing and grading of construction site, an evaluation of the following factors must be carried out:
 - a. Soil Erodibility - Soil credibility should be identified using Soil Conservation Service credibility ratings. Erosion control techniques shall be designed accordingly.
 - b. Slope and Runoff - Cleared areas will require protection from erosion.
 - c. Cover - Erosion protection will be required for all disturbed areas.

Temporary facilities may include silt fences, drain barriers, gravel entries, ditches, surface stabilization or other devices as necessary.

Temporary/permanent hydro-seeding or acceptable seeding and mulching must be provided whenever perennial cover cannot be established on sites which will be exposed after September 1 or prior to June 1.

3.0060 - PRIVATE DRAINAGE SYSTEMS

3.0061 - SUBDIVISIONS

When subdivision lots drain to the rear, it may be necessary to provide a private drainage system in private easements. This system shall be for collection of roof drains, footing drains and surface runoff. This system shall be designed to meet the Uniform Plumbing Code requirements.

3.0062 - SUBSURFACE DRAINAGE

Subsurface drains (under drains) shall be provided at the following locations:

- a. For all existing springs and field tile intercepted during construction activity for other facilities, i.e. sewer, water, mains, street excavations, foundations, etc. Subsurface drains are not needed if the tile is removed.
- b. Where high ground water exists or when it is necessary to reduce the piezometric surface to an acceptable level to prevent land slippage or under floor flooding of buildings.
- c. The drainage line installed shall begin at a clean-out and terminate at an approved point of disposal. Open jointed storm drain lines will not be considered as an acceptable solution.

3.0070 - WATER QUALITY

Stormwater runoff will be treated prior to being discharged from the site under the following criteria.

- a. No water quality treatment will be required for developments not requiring detention under 3.0041 of this section.
- b. The treatment volume will be the runoff from a 0.36" rainfall distributed over four hours.
- c. Treatment facilities may be incorporated into other facilities required within this section (i.e. detention ponds).
- d. A maintenance schedule or plan should be included with the design calculations. The plan can be part of the detention pond maintenance plan.

CITY OF MOLALLA PUBLIC WORKS DESIGN STANDARDS

SECTION: 4.0000 - SANITARY SEWERS

4.0010 - GENERAL DESIGN REQUIREMENTS

Performance Standards - Sanitary sewer system design shall meet the policies and guidelines of the current Oregon Administrative Rules (OAR), and the Oregon Department of Environmental Quality (DEQ) guidelines.

Sanitary sewer systems shall be designed to provide gravity service to all areas of development where public. Pump stations are acceptable only if it is not possible to provide gravity service

Sanitary sewer system capacity shall be designed for ultimate development density of the tributary area. The system shall allow for future system extension and for future development.

Sanitary sewers shall be designed to remove the domestic sewage and industrial wastes from basements of houses, where practical, commercial or industrial buildings, and all public and private establishments where possible.

Storm water, including street, roof or footing drainage, shall not be discharged into the sanitary sewer system, but shall be removed by a system of storm drains or by some other method separate from the sanitary sewer system.

Unpolluted or non contact cooling waters shall not be discharged into sanitary sewers. The overflow drains and filter backwash lines of swimming pools and "hot tubs" shall drain into a sanitary sewer.

As a condition of sewer service, all developments will be required to provide public sewers to adjacent upstream parcels in order to provide for an orderly development of the drainage area. This shall include the extension of sewer mains in easements across the property to adjoining properties and across the street frontage of the property to adjoining properties when the main is located in the street right-of-way. This shall include trunk sewers that are oversized to provide capacity for upstream development.

All sewer service lines shall be extended a minimum of ten ft. (10') beyond the last property served within the subdivision.

All sewer lines shall be located within the public right-of-way as directed by the Public Works Director. These lines are placed in the public right-of-way for ease of maintenance, access, control of the facility operation of the facility, and to provide required replacement and/or repair.

Where sewers are constructed on slopes greater than 20%, in areas designated as hazardous or where there are site conditions that may cause damage to improvements, slippage or slides as determined by the Public Works Director, a soils and/or geologic report may be required.

Where the finished graded surface is greater than twenty (20) percent, or as required by the Public Works Director, soil stabilization fabric shall be placed over the entire disturbed area.

Standard specifications and drawings relevant to this section may be found in the most current edition of the APWA Standard Specifications for Public Works Construction, Oregon Chapter.

4.0011 - PIPE MATERIALS AND SIZE

All public sanitary sewers shall be constructed with PVC or HDPE pipe as specified in the appropriate section of the Molalla Standard Specifications. Where required for added strength, epoxy-lined ductile iron pipe may be used. PVC pipe and fittings shall conform to ASTM D-3034, SDR 35.

d. A pumping station may be substituted with approval of the Public Works Director.

4.0023 - SEPARATION WITH WATER LINES

Mains shall be installed a minimum clear distance of ten feet (10') horizontally from water lines and shall be installed to go under water lines with a minimum of 18 inches of clearance at intersections of these pipes. Exceptions shall first be approved by the Public Works Director. In all instances the distances shall be measured edge to edge. The minimum spacing between water mains and storm drains, gas lines, and other underground utilities, excepting sanitary sewers, shall be three feet (3') horizontally when the standard utility location cannot be maintained.

4.0024 - EASEMENTS

Sewers placed in easements along a property line shall have the easement centered on the property line and the sewer shall be offset 18 inches from the property lines. For sewers placed in easements located other than along a property line, the sewer shall be placed in the center of the easement. The conditions of the easement shall be such that the easement shall not be used for any purpose which would interfere with the unrestricted use for sewer main purposes. Under no circumstances shall a building or structure be placed over a sanitary sewer main or sewer easement. This shall include overhanging structures with footings located outside the easement. Further, no trees or large bushes shall be planted in the easement.

Easements for sewers less than 12 inches in diameter shall have a minimum width of fifteen feet (15'). Sewers greater than 12 inches in diameter shall have a minimum easement width of twenty feet (20').

Sewers with more than eight feet (8') of cover and/or inside diameters 24 inches or greater will require wider easements. A slope of one horizontal to one vertical from the sewer invert to ground surface will be used to determine easement width. Easement widths shall vary from the fifteen foot (15') minimum by five foot (5') increments; for instance, 15, 20, 25 feet.

Easement locations for public sewer mains serving a PUD, apartment complex, or commercial/industrial development shall be in parking lots, private drives, or similar open areas which will permit unobstructed vehicle access for maintenance by City personnel.

All easements must be furnished to the City for review and approval prior to recording.

4.0025 - RELATION TO WATERCOURSES

Generally, the top of all sanitary sewers entering, crossing or adjacent to streams, irrigation ditches or drainage ways shall be at a sufficient depth below the natural bottom of the waterway to protect the sewer line. One foot (1') of cover is required where the sewer is in rock, three feet (3') of cover is required in other materials. In paved channels, the top of the sewer line shall be placed at least six inches (6") below finish grade of the batten of the channel, except as provided above.

Sewers located along streams shall be located outside of the stream bed and sufficiently removed therefrom to provide for future possible stream channel widening. All manhole covers shall be watertight, at or below the 100 year flood elevation.

Sewers crossing streams or drainage channels shall be designed to cross the stream as nearly perpendicular to the stream channel as possible and shall be free from change of grade. The minimum cover shall be 36 inches from the bottom of the stream bed or drainage channel.

Pipe material shall be ductile iron with an 18-foot length of pipe centered on the stream or drainage channel centerline. The ductile iron pipe shall extend to a point where a one-to-one slope, which begins at the top of the bank and slopes down from the bank away from the channel centerline, intersects the top of the pipe.

A scour pad centered on the sewer line will be required when the top of the pipe to the bottom of the stream or drainage channel is thirty inches (30") or less. The scour pad shall be concrete, six inches (6") thick and six feet (6') wide, reinforced with number four (4) rebar twelve inches (12") on center both ways and shall extend to a point where a one-to-one slope, that begins at the top of the bank and slopes down

Private sanitary sewers shall meet the appropriate sections of the Uniform Plumbing Code (UPC.)

All sanitary sewer main lines shall be a minimum diameter of eight inches (8"). Six inch (6") diameter sewer for non extendible sewers of up to 250 feet in length serving eight (eight) lots or less may be permitted with approval.

4.0012 - MINIMUM DESIGN CRITERIA

Velocity - All sanitary sewers shall be designed on a grade which produces a mean velocity, when flowing half-full or full, of no less than two feet (2") per second.

Manning Equation - When calculating minimum pipe slopes and velocities, the engineer shall use the manning pipe friction formula.

Pipe Coefficient - The minimum pipe roughness coefficient for sanitary sewers shall be 0.013.

4.0020 - ALIGNMENT AND COVER

4.0021 - RIGHT OF WAY LOCATION

Sanitary sewer lines shall be located five feet (5') north and west from the right-of-way centerline. All changes in direction of pipe shall be made at a manhole.

Sewers shall be located in the street right-of-way. If streets have curved alignments, the center of the manhole shall not be less than six feet (6') from the curb face on the outside of the curve nor the sewer centerline less than six feet (6') from the curb face on the inside of the curve.

Curved alignments in sanitary sewers are not permitted.

4.0022 - MINIMUM COVER

All sanitary sewers shall be laid at a depth sufficient to drain building sewers, to protect against damage by frost or traffic, and to drain basement sewers, where practical. Sufficient depth shall mean the minimum cover from the top of the pipe to finish grade at the sewer alignment. In new residential hillside subdivisions, mainline and lateral sewers shall be placed in the street at a depth sufficient to drain building sewers on the low side of the street.

Sanitary sewers in residential areas shall be placed in the street with the following minimum cover:

Building Service Lateral- Six feet (6')
Trunk and Collector Sewer in the roadway - Eight feet (8')
In easements - Eight feet (8')

Where pipes cross under ditches or streams and the cover is less than three feet (3'), extra protection will be required as discussed in Section 4.0025.

Where the topography is relatively flat and existing sewers are shallow (five feet (5') or less), the minimum cover shall be three feet (3').

Deviation from the above standards will be considered on a case-by-case basis when one of the following circumstances exist:

- a. Underlying rock strata - required: A request in writing to the Public Works Director together with submittal of a soils report with a plan and profile certifying that bed rock exists three feet (3') below the undisturbed ground surface at all investigated alignments.
- b. A ditch or stream must be crossed - required: A plan and profile; horizontal scale 1" = 20'. vertical scale 1" = 2'.
- c. Where three ft. (3') of cover is not possible, the sewer line shall be epoxy-lined ductile iron.

from the bank away from channel centerline intersects the top of the pipe. Each deviation from the above requirements will be reviewed on a case-by-case basis.

4.0030 - STRUCTURES

4.0031 - MANHOLES

Manholes shall conform to ASTM C-478.

Manholes shall be located at changes in slope, alignment, pipe size, and at all pipe junctions with present or future sanitary sewers.

Manhole spacing shall not be greater than 400 feet.

The angle between incoming and out going sewer lines shall be greater than 80-degrees.

Designs for manholes are shown in the Standard Drawings. They are suitable for most conditions. New designs or revisions should not be shown on the construction drawings unless the standard designs are not suitable. New or revised designs may be necessary if:

- a. One or more of the sewers to be connected to the manhole is over 36 inches in diameter. Smaller diameters may require a special design if the manhole is at an alignment change.
- b. Several sewers will be connected to the manhole.
- c. There is less than 80 degrees between the incoming and outgoing sewer.
- d. The manhole will be subject to unusual structural loads.
- e. Diversion or other flow control measures are required.

Where one or more of conditions a), b), or c) are encountered, a drawing of the manhole base should be made to determine if it is feasible to use designs shown in the Standard Drawings. It may be necessary to restrict the options to a specific Standard Drawing specified by a note on the construction drawings. If a special design is required for any reason, it will be necessary to show the details on the construction drawings and to provide structural calculations as needed.

Some alternate manhole features are shown in the Standard Drawings. Where these features are required, they must be specified by a note on the construction drawings. Some examples are:

- a. Flat tops must be used in lieu of cones where there will be less than four feet (4') between the manhole shelf and the top of the manhole
- b. Watertight manhole frames and covers are to be used if flood waters are expected to cover the manhole top or if the manhole must be located in the street gutter. Such conditions should be avoided wherever feasible.
- c. Tamper-proof manhole frames and covers are required in areas subject to vandalism, such as areas which are not readily visible to the general public or the property occupants.

Standard for elevation differences at manholes have been established to compensate for normal energy losses and to prevent surcharging of a sewer by a larger sewer. For purposes of slope calculation and for establishing elevation differences, the elevations are given at the intersection of the sewer centerline (usually the center of the manhole). The rules for elevation differences at manholes are:

- a. The crowns of incoming sewers shall be at least as high as the crown of the outgoing sewer.
- b. If the incoming and outgoing sewers are of equal size and are passing straight through the manhole, no added elevation change is required.

- c. If sewers intersect or the alignment changes at the manhole, the invert elevation difference shall be at least 0.10 feet for 0°-45° of horizontal deflection angle, and 0.20 feet for over 45° of horizontal deflection angle.
- d. The slope of a sewer within a manhole shall be no less than the slope of the same sewer outside of the manhole.
- e. Where the difference between the slope of the incoming and out going pipe is greater than six percent (6%), the slope across the manhole shall be the average of the incoming and outgoing pipes.
- f. Drop connections are required when the vertical distance between flow lines exceeds two feet (2'). The diameter of the drop connection must be specified on the construction drawings. The diameter of the drop connection shall not be more than one pipe size smaller than the diameter of the incoming sewer. Smooth flow lines with vertical distances of less than one foot (1') must be provided wherever feasible. Drop connections shall be outside drops.
- g. All connections must enter the manhole through a channel in the base. This includes drop connections and connections to existing manholes.

Where conditions make compliance with these rules impractical, exceptions will be permitted. It will be necessary, however, for the designer to provide a complete analysis of the need for such designs.

4.0032 - CLEAN OUTS

Cleanouts will not be approved as substitutes for manholes on public sewer lines. Clean outs are permitted at the upper end of a sewer that will be extended during a future construction phase. When the sewer is extended, the clean out will be removed and a manhole shall be installed in the appropriate location. If future extension requires a change in sewer alignment or grade, a manhole will be required at the cleanout location.

Cleanouts are permitted at the end of a non-extendable sewer line that does not exceed 250 feet in length nor serve more than eight lots (8).

4.0033 - ANCHOR BLOCKS

For sewer pipes greater than four inches (4") in diameter, concrete anchor blocks shall be required if the slopes are greater than twenty percent (20%). Anchor blocks shall key into trench sides. Spacing for anchor blocks is as follows:

SPACING FOR ANCHOR BLOCK FOR ALL SIZE PIPE

SLOPE %	MINIMUM SPACING (FT)
0 - 19.99	NO ANCHOR REQUIRED
20 - 34.99	35
35 - 50.99	25
51 - OR MORE	15 OR SPECIAL DESIGN

4.0034 - WATER BARS

Where the finished graded surface has a slope greater than or equal to 3 units horizontal to 1 unit vertical or as required, water bars shall be installed. The water bars shall be sloped slightly to drain runoff water away from the pipe line alignment. Water bars shall have a maximum spacing of forty feet (40').

4.0040 - SERVICE LATERAL

Service laterals are those public sewer lines to which a private building sewer connects. Service laterals are to be built to the same construction standards and of the same materials as the sewer mainline.

Each individual building site shall be connected by a separate private building sewer service line connected to the public sewer. Combined sewer service lines will be permitted only when the property cannot legally be further divided. Examples of this is a residential lot with a house and an unattached garage or shop with plumbing facilities.

The minimum inside diameter of a sewer service lateral shall be four inches (4") and shall be equal to or greater than the building sewer diameter. Service laterals in general shall be placed at 90° to the main sewer line to avoid excessive exposure to other utilities during excavation for construction or maintenance of the service lines. Angles other than 90° may be approved for special conditions such as cul-de-sac lots. In no case shall the angle between the main and the service be less than 90°. Service line connections shall not be made at manholes except at cul-de-sacs.

The minimum slope of sewer service lines shall be 2 percent (1/4 inch per foot) except that for unusual conditions, a slope of 1 percent (1/8 inch per foot) may be approved. It will be necessary, however, for the designer to provide a complete analysis of the need for any sewer service lateral slope less than 2.00 percent. The maximum slope shall be 100 percent (45° or one foot per foot). Deep connection risers (see the Standard Detail for service lateral to deep sewers) or drop connections to manholes must be used where service line slopes would exceed 100 percent.

Tees for service laterals shall be installed at 100% slope, and 1/16 or 1/8 bends shall be installed to provide proper grade for service lateral. Service laterals shall be extended to the end at street right-of-way line or easement line, when a sewer is installed in easement. A water tight plug shall be installed in end of lateral and a 2" x 4" wood marker shall be placed at lateral end from pipe invert to two feet (2') above the ground. 2" x 4" top to be painted white and marked with the depth of the lateral measured from ground to invert of pipe.

4.0050 - CONNECTION TO EXISTING SEWERS

Connections to, and extensions of, existing sewers will occur to facilitate new development.

Connections to existing manholes shall be made with the following guidelines:

- a. Where the invert of the connecting pipe is two feet or less above the manhole shelf, a beaver slide will be constructed utilizing Portland Cement concrete. The sewage entering the manhole will follow a smooth concrete channel transitioning evenly from the invert of the inlet pipe into the main channel. Sewage will not be allowed to fall freely to the manhole base.
- b. Where the invert of the connecting pipe is more than two feet above the manhole shelf, the contractor will be required to construct an inside drop with the inlet pipe invert being located at the manhole shelf. The sewage entering the manhole will follow a smooth concrete channel transition from the inlet pipe into the main channel.
- c. Where the invert is required to enter below the shelf of the manhole, the inlet pipe will not enter below a point where the crown of the new inlet pipe is below the crown of the outlet pipe. The base of the manhole will be rebuilt if damaged in this process. The sewage will enter the main flow in a smooth channel transitioning from the inlet pipe to the main channel.
- d. No pipe will enter an existing manhole where the angle between the incoming flow and the outgoing flow is greater than 90°.

When sewers are extended from cleanouts, the entire cleanout assembly, including the wye, shall be removed.

New building service laterals will be made at existing tees where possible.

When tees do not exist on the Public Sanitary Sewer System, the new lateral sewer will enter the collection system through a "cored" opening with an approved connector.

4.0060 - PRIVATE SEWER LINES

Private sewer systems shall be constructed in accordance with the UPC.

4.0070 - SYSTEM TESTING

All pipe shall be pressure tested and manholes leak tested per the latest edition of the APWA Standard Specifications for Public Works Construction, Oregon Chapter.

4.0080 - SEWAGE PUMP STATION DESIGN STANDARDS

4.0081 - GENERAL

The pump station shall be a ground level self priming pump type facility.

The station shall be designed by an engineer registered in the State of Oregon and experienced in the design of such facilities. Service area peak flows, pump station cycle and hydrogen sulfide calculations shall be submitted to the City for review and approval.

4.0082 - CONSTRUCTION

Station construction will include: wet well, pump enclosure, associated piping and valves, electrical controls, automatic dialer, visual alarm, emergency power transfer switch and connection receptacle, lighting, heater, ventilating fan, instrumentation, access road, fencing, landscaping, potable water supply, and shall conform to the Department of Environmental Quality (DEQ) standards and Oregon Administrative Rules (OAR) Chapter 340, Division 52. The standard type pump station shall be equal to Hydronix package pump stations.

4.0083 - CAPACITIES

Pump station shall be designed to pump the peak waste water flow from the service area. When the service area is not built out, staging of pump station capacity will be allowed. The wet well shall be sized to allow for a minimum number of starts per hour. Inlet piping will not be used as a portion of the wet well.

4.0084 - HYDROGEN SULFIDE

Calculations for hydrogen sulfide production shall be performed. Hydrogen sulfide control equipment shall be installed as required. The method used (flow back, air injection, chemical injection) shall be reviewed and approved by the Public Works Director.

4.0085 - ELECTRICAL

a. Electrical

Pump station and related facilities will be constructed to Electrical and Building Codes.

Electrical controls shall be located above ground mounted in a waterproof enclosure. Electrical panels shall be listed. The pump station wet well shall be considered a hazardous location. Level controls in the wet well shall be intrinsically safe.

b. Controls

Controls may be mechanical relays or programmable logic-controllers. Pumps shall automatically alternate lead-lag position with each pumping cycle.

Pump level control shall be by multi-trode.

4.0090 - EROSION CONTROL

Erosion control will be required for all areas disturbed during construction and following construction until permanent protection is established.

Temporary facilities may include silt fences, drain barriers, gravel entries, ditches, surface stabilization or other devices as necessary.

Temporary/permanent hydro-seeding or acceptable seeding and mulching must be provided whenever perennial cover cannot be established on sites which will be exposed after September 1 or prior to June 1.

c. Power

An auxiliary power generator shall be provided with a manual transfer switch mounted in the interior.

Alarms include:

Pump failure
Power failure
Telemetry failure
High water level
Generator Failure

4.0086 - MATERIALS

a. Pumps

A minimum of two pumps shall be supplied. Each pump shall be capable of pumping the peak waste water flow. Where more than two pumps are used, the station shall be able to pump peak waste water flow when the largest pump is out of service.

Pumps shall be self priming pumps, with V-belt drives, manufactured by Hydromatic, Gorman Rupp or equal, explosion-proof suitable for hazardous location when required, and shall be UL or FM listed.

b. Piping and Valves

Piping and fittings shall be ductile iron to a point at least two feet (2') outside the station. Valves shall be metal, suitable for wastewater use. Valves shall be designed for wastewater service. Provide pressure gages with isolation and purge valves on pump suction and discharge piping.

Steel fabrications shall be hot dipped galvanized. Painting is required on valves, piping, and pipe fittings.

Force main shall be designed for nominal flow velocity in the range of 3 to 5 ft/sec.

Force mains shall not be less than four inches (4") in diameter for raw sewage.

c. Spare Parts

Supply two sets each of all gaskets, bearings, V-belts, and mechanical seals for rotation equipment.

4.0087 - ADDITIONAL FEATURES

Provide 1-inch anti-freeze hose bibb. Potable water shall be provided by an above ground reduced pressure back flow Preventer.

Provide positive ventilation in the enclosure.

Provide odor control as required.

Landscaping will only be required when the station is visible from the public roadway and then only to blend with the local aesthetics.

A 6-foot chain link fence shall surround the pump station when required by the Public Works Director.

4.0088 - OPERATING AND MAINTENANCE DATA

Compile product data and related information appropriate for City's maintenance and operation or products furnished under the contract.

Prepare operations and maintenance manual.

Instruct City's personnel in the maintenance of products and in the operation of equipment and systems.

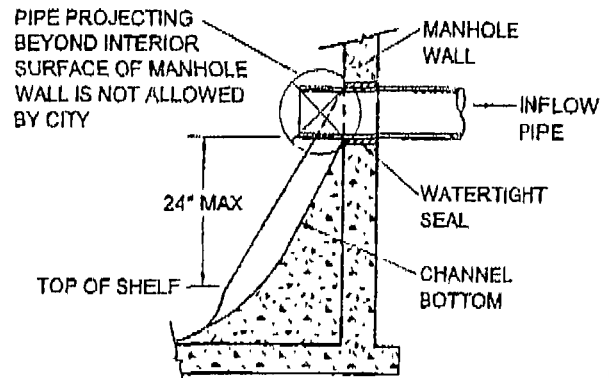
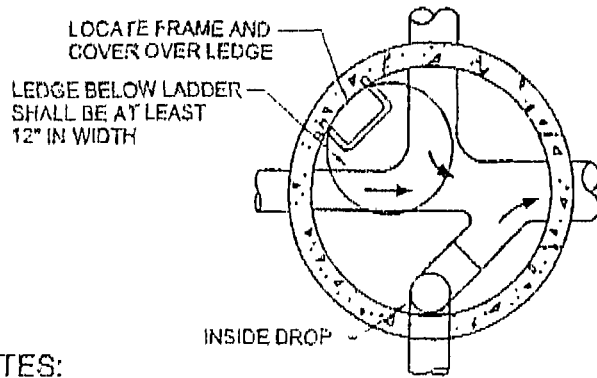

OPEN INSIDE DROP WITH BEAVER SLIDE

NOTES:

1. All manhole 60-inch riser sections shall conform to the requirements of ASTM C-478 and applicable provisions of *Beaverton Standard Dwg 304*.
2. A single "open" (unenclosed) inside drop with a "BEAVER SLIDE" may be allowed with prior approval of city engineer.
3. The city does not allow outside drops, "open" (unenclosed) inside drops over 2 feet high, or partitioned inside drops.
4. Pipe and fittings for drop assembly shall be same size as inflow pipe to manhole.
5. Pipe and fittings for drop assembly shall be: ductile iron ANSI A21.50-1, AWWA C150-1, AWWA C-900 or PVC ASTM 3034 SDR 35.
6. Pipe connections of four or more mainlines shall require a manhole connection and channel detail.
7. Provide a minimum of 8-inches of intact (undisturbed) manhole wall between pipe breakouts as measured on the inside face of the manhole.
8. No more than 8-inches of riser rings shall be used.
9. Minimum fall between inlet and outlet to be not less than 0.10 feet.
10. See *Clean Water Services Standard Dwg 080* for clamp detail.
11. The city reserves the right to deviate from this drawing and related requirements in the *Engineering Design Manual* as dictated by project design parameters, and as approved by the City Engineer.

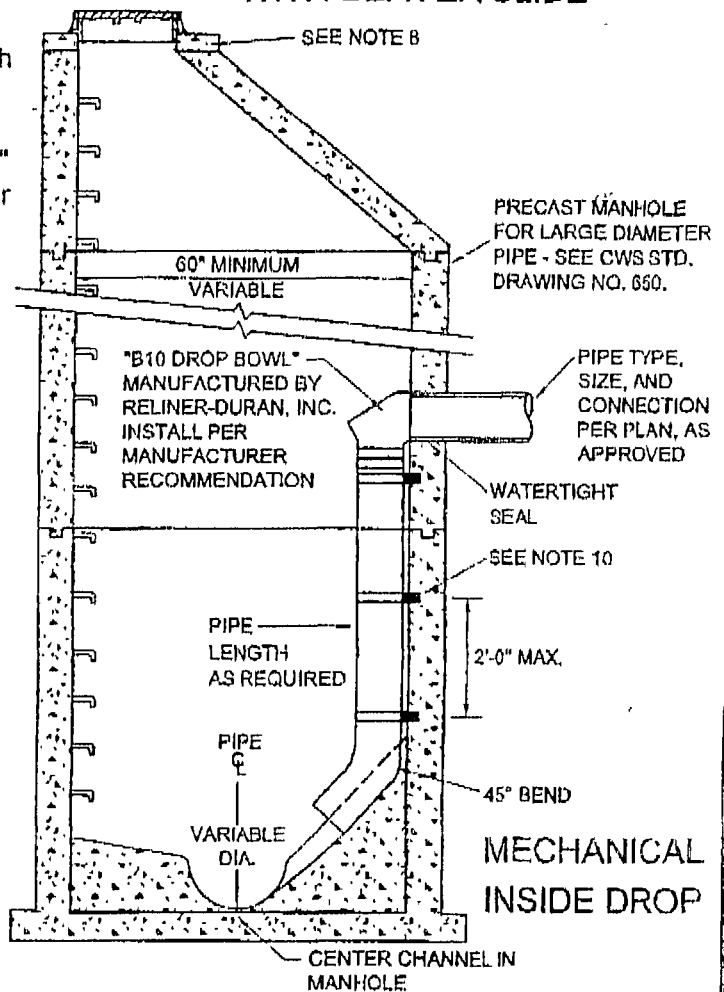

MECHANICAL INSIDE DROP

SANITARY SEWER INSIDE DROP
 REPLACES CWS (USA) STANDARD DETAILS NO. 070 AND 080
 BY BEAVERTON ORDINANCE #4303



City Of Beaverton

**ENGINEERING
DEPARTMENT**

**SANITARY SEWER
INSIDE DROP MANHOLE**

CITY ENGINEER
Terry Waldele, P.E.

DATE
6 - 10 - 04

DRAWN BY
JCH - CPD

DRAWING NO.
306

CITY OF MOLALLA PUBLIC WORKS DESIGN STANDARDS

SECTION 5.0000 - WATER MAINS

5.0010 - GENERAL DESIGN REQUIREMENTS

Performance Standards - Water distribution systems shall be designed to meet State Water Administrative Rules and guidelines of the Water System Master Plan and its updates.

Water system design shall provide adequate flow for fire protection and maximum water usage and consumption. Required water system demands shall be met by maintaining the minimum operating pressures required by the City. For single family residential areas the minimum static pressure shall be 40 psi, and the minimum fire flow shall be 1000 gpm. For all other developments, the required fire flow shall be as determined by the Fire Chief.

Water system design shall meet distribution needs for maximum water usage and consumption within a given service area. New water systems shall be extended to the far side of the property to allow for future extensions beyond present development and to be consistent with the Master Plan.

All water lines shall be located within the public right-of-way or as directed by the Public Works Director. These lines are placed in the public right-of-way for ease of maintenance and access, control of the facility, operation of the facility, and to permit required replacement and/or repair. The Public Works Director, under special conditions, may allow a public water line to be located within a public water easement as referenced in Section 5.0024.

Where water lines are constructed on slopes greater than 20%, in areas designated as hazardous or where there are site conditions that may cause damage to improvements, slippage or slides as determined by the Public Works Director, a soils and/or geologic report may be required.

Where the finished graded surface is greater than twenty percent (20%), or as required by the Public Works Director, soil stabilization fabric shall be placed over the entire disturbed area.

Standard specifications and drawings relevant to this section may be found in the most current edition of the APWA Standard Specification for Public Works Construction, Oregon Chapter.

5.0011 - PIPE MATERIALS AND SIZE

All public water distribution systems shall be constructed with C900 PVC pipe, Class 150. Alternatively, water mains may be constructed with ductile iron pipe, minimum thickness as shown in the following table.

Pipe size (inches)	D.I. Class
8 and smaller	52
10	51
12	50

All ductile iron pipes shall be cement mortar-lined pipe with push-on or mechanical type joints. When a corrosive potential condition is encountered, all ductile iron pipe and fittings will be polyethylene encased with a 8 mil tubing meeting manufacturer and AWWA standards. Where an active cathodic protection system is encountered as a result of other utilities, a deviation from the normal pipe design material/installation practice may be required by the Public Works Director.

All valves and fittings shall be ductile iron or cast iron, conforming to AWWA specifications. All fittings shall be factory cement lined and coated. Pipe constructed per Section 5.0025 will require the use of restrained pipe joints or ball and socket river pipe.

Service lines shall be as shown in the following table.

Service Pipe Size (inches)	Pipe Material
2 and Smaller	Type K Copper Tubing
3 and Larger	Ductile Iron or C900 PVC

Water distribution main sizes shall conform to the following:

- 6-inch Minimum size residential subdivision distribution water main shall not exceed an unsupported length of 600 feet. Looping of the distribution grid shall be at least every 600 feet.
- 8-inch Minimum size for permanently dead-ended mains supplying fire hydrants with a fire flow less than 1,500 gpm and for primary feeder mains in residential subdivisions.
- 10-inch & up As required for primary feeder lines in subdivisions, industrial and commercial areas.

Water service lines shall conform to the following:

- 3/4" Residential services.
- 1" and up Public, Commercial, Industrial and other non-residential uses shall be sized per actual usage.

Velocity in distribution mains shall be designed not to exceed five feet (5') per second. Velocity in service lines (as defined in Section: 5.0050) shall not exceed ten feet (10') per second.

5.0012 - GRID SYSTEM

The distribution system mains shall be looped at all possible locations. All developments will be required to extend mains across existing or proposed streets for future extensions by the City or other developments. All terminations shall be planned and located such that new or existing pavement will not have to be cut in the future when the main is extended. The installation of permanent dead-end mains greater than 250 feet upon which fire protection depends and the dependence of relatively large areas on single mains will not be permitted.

5.0013 - DEAD-END MAINS

Dead-end mains which will be extended in the future shall be provided with a line-size gate valve and MJ plug at the end and tie rodded. The valve plug shall be tapped 2" and provided with a standard blow-off, except that the 2" gate valve shall not be installed.

Permanent dead-end mains shall terminate with a standard blow-off assembly.

5.0020 - ALIGNMENT AND COVER

5.0021 - RIGHT-OF-WAY LOCATION

Water systems shall be located twelve feet (12') south and east from the right-of-way centerline or as directed by the Public Works Director. Except as provided in Section 5.0024, all water lines shall be in the public right-of-way. All abrupt changes in vertical or horizontal alignment shall be made with a concrete thrust block or a megalug or MJ grip ring as required by the Public Works Director. Curved alignment for water lines or mains is permitted and shall follow the street centerline when practical. The minimum allowed radius shall be based on allowable pipe deflection for the pipe diameter and the pipe laying length but not to exceed 3° joint deflection.

5.0022 - MINIMUM COVER

The standard minimum cover over buried water mains within the street right-of-way or easements shall be thirty-six inches (36") from finish grade.

Finish grade shall normally mean the proposed pavement or ground elevation where the main is located.

Deviation from the above standards will be considered on a case-by-case basis when the following exists:

- a. When there is underlying rock strata that prohibits placement of the water main thirty-six inches (36") below finish grade, a written request must be submitted to the Public Works Director together with submission of a soils report with a plan and profile certifying that bed rock exists less than three feet (3') below the undisturbed ground surface.

5.0023 - SEPARATION WITH SEWER LINES

Water mains shall be installed a minimum clear distance of ten feet (10') horizontally from sanitary sewers and shall be installed to go over the top of such sewers with a minimum of eighteen inches (18") of clearance at intersections of these pipes. Exceptions shall first be approved by the Public Works Director. In all instances, the distances shall be measured edge to edge. The minimum spacing between water mains and storm drains, gas lines, and other underground utilities, excepting sanitary sewers, shall be three feet (3') horizontally when the standard utility location cannot be maintained.

Where water lines are being designed for installation parallel with the other water mains, utility pipe, or conduit lines, the vertical separation shall be twelve inches (12") below or in such a manner which will permit future side connections of mains, hydrants, or services and avoid conflicts with parallel utilities without abrupt changes in vertical grade of the above mentioned main, hydrant, or service. Where crossing of utilities are required, the minimum vertical clearance shall be six inches (6").

5.0024 - EASEMENTS

Mains placed in easements along a property line shall have easements centered on the property line and shall be offset eighteen inches (18") from the property line. For mains placed in easements located other than along a property line, the main shall be placed in the center of the easement. Easements, when required, shall be exclusive and a minimum of fifteen feet (15') in width. The conditions of the easement shall be such that the easement shall not be used for any purpose which would interfere with the unrestricted use for water main purposes. Under no circumstances shall a building or structure be placed over a water main or water main easement. This includes overhanging structures with footings located outside the easement. Further, no trees or large bushes shall be planted in the easement.

Easement locations for public mains serving a PUD, apartment complex, or commercial/industrial development shall be in parking lots, private drives, or similar open areas which will permit unobstructed vehicle access for maintenance by City personnel.

Any water main placed within a water main easement will be permanently marked with steel posts and metal signs at all angle points and no less than every 100 feet. In addition, such posts and signs shall be placed where the water line intersects the public right-of-way at the easement location. A monument cap set in the pavement of parking lots shall be an acceptable alternative to the sign. The City shall provide wording for the sign/monument.

All easements must be furnished to the City for review and approval prior to recording.

5.0025 - RELATION TO WATERCOURSES

New water mains may cross over or under existing streams, ponds, rivers, or other bodies of water.

- a. Above Water Crossings - The pipe shall be engineered to provide support, anchorage, and protection from freezing and damage, yet shall remain accessible for repair and maintenance. All above water crossings will require review and approval by the Public Works Director.

1. Valves shall be provided at each end.

2. Air/Vacuum relief valves shall be provided.

b. Underwater Crossings

1. Mains crossing stream or drainage channels shall be designed to cross as nearly perpendicular to the channel as possible.
2. Valves shall be provided at both ends of the water crossing so that the section can be isolated for testing or repair. The valves shall be easily accessible and not subject to flooding. The valve nearest to the supply source shall be in a manhole. Permanent taps shall be made on each side of the valve within the manhole to allow insertion of a small meter for testing to determine leakage and for sampling.
3. The minimum cover from the bottom of the stream bed or drainage channel to the top of pipe shall be thirty-six inches (36").
4. A scour pad centered on the water line will be required for the top of the pipe to the bottom of the stream bed or drainage channel is thirty inches (30") or less. The scour pad shall be concrete, six inches (6") thick and six feet (6') wide, reinforced with number four bars twelve inches (12") on center both ways and shall extend to a point where a one-to-one slope, that begins at the top of the bank and slopes down from the bank away from channel centerline intersects the top of the pipe.

c. The following surface water crossings will be treated on a case-by-case basis:

1. Stream or drainage channel crossing for pipes twelve inches (12") inside diameter and greater
2. River or creek crossings requiring special approval from the Division of State Lands.

5.0030 - APPURTENANCES

5.0031 - VALVES

In general, valves up to 10-inch shall be the same size as the mains in which they are installed.

Main line valves shall be resilient seated gate valves meeting the requirements of AWWA C509.

Main line valves 12-inch and larger shall be butterfly valves conforming to AWWA C504.

Distribution system valves shall be located at all tee or cross fitting. There shall be a sufficient number of valves so located that not more than four (4) and preferably three (3) valves must be operated to effect any one particular shutdown. The spacing of valves shall be such that the length of any one shutdown in commercial or industrial areas shall not exceed 500 feet nor 800 feet in other areas.

In general, a tee-intersection shall be valved on all branches and a cross-intersection shall be valved on all branches. Transmission water mains shall have valves at not more than 1,000 foot spacing. Hazardous crossings, such as creek, railroad and highway crossings, shall be valved on each side.

Distribution tees and crosses with valves for future branch lines on transmission mains may be required at the direction of the Public Works Director.

5.0032 - FIRE HYDRANTS

The public fire hydrant system shall be designed to provide up to a maximum of 3,500 GPM. The distribution system shall be designed in commercial/industrial areas to accommodate fire flows up to 4,500 GPM or as required by the Fire Chief. Minimum fire flow in single family residential areas shall be 1500 GPM.

The distribution of hydrants shall be based upon the required average fire flow for the area served. Design coverage shall result in hydrant spacing of approximately 500 feet in residential areas,

approximately 300 feet in commercial or industrial subdivisions or as approved by the Fire Chief and Public Works Director. In addition, sufficient hydrants shall be available within 1000 feet of a building in commercial/industrial areas to provide its required fire flow.

Residential hydrants shall be located as nearly as possible to the corner of street intersections and not more than 500 feet from any cul-de-sac radius point.

No fire hydrant shall be installed on a main of less than eight inches (8") inside diameter unless it is in a looped system of six-inch (6") mains. The hydrant lead shall be minimum six-inch (6") inside diameter.

All fire hydrants will be located behind the existing or proposed curb. If any public hydrant encroaches on private property an easement will be provided as directed by the Public Works Director.

No hydrant shall be installed within five feet (5') of any existing aboveground utility nor shall any utility install facilities closer than five feet (5') from an existing hydrant.

Full-depth hydrants will be required in all installations. Installation of hydrant extensions will require Public Works Director approval.

Each fire hydrant shall have an auxiliary valve and valve box which will permit repair of the hydrant without shutting down the main supplying the hydrant. Such auxiliary valves shall be resilient seat gate valves. The auxiliary valve shall have mechanical joint-flange ends. The valve shall be connected directly to the water main using a flange joint tee, tie rods, and thrust blocked.

Hydrants shall not be located within twenty feet (20') of any building, nor will they be blocked by parking. The large hydrant port should face the road or travel way. Hydrant shall have 2 2-1/2" ports and 1 4-1/2" port. All Fire Hydrants provided shall be Mueller Centurion.

Guard posts a minimum of three feet (3') high shall be required for protection from vehicles when necessary. Such protection shall consist of four-inch (4") diameter steel pipes six feet (6') long filled with concrete and buried a minimum of three (3') feet deep in concrete and located at the corners of a six (6') foot square with the hydrant located in the center. Use of posts other than at the four corners may be approved by the Public Works Director.

5.0033 - PRESSURE-REDUCING AND AIR RELEASE VALVES

Where water systems cross pressure zone lines, a pressure-reducing valve station will be required. The specific design and location for such valves will be reviewed and approved by the Public Works Director.

When designated by the Public Works Director, air release valves shall be installed. Such valves will be required on large diameter lines at all high points in grade.

5.0034 - RAILROAD OR HIGHWAY CROSSINGS

All such crossings defined above, or as determined by the City to be of a hazardous nature, shall be valved on both sides of the crossing. Casing of railroad or highway crossings, if required, shall be as noted in the permit from the respective agency.

5.0035 - ANCHOR BLOCKS

For water pipes greater than four inches (4") in diameter, concrete anchor blocks shall be required if the slopes are greater than twenty percent (20%). Anchor blocks shall key into trench sides. Spacing for anchor blocks is as follows:

SPACING FOR ANCHOR BLOCK FOR ALL SIZE PIPE

SLOPE %	MINIMUM SPACING (FT)
0 - 19.99	NO ANCHOR REQUIRED
20 - 34.99	35
35 - 50.99	25
51 - OR MORE	15 OR SPECIAL DESIGN

5.0036 - WATER BARS

Where the finished graded surface has a slope greater than or equal to 3 units horizontal to 1 unit vertical or as required, water bars shall be installed. The water bars shall be sloped slightly to drain runoff water away from the pipe line alignment. Water bars shall have a maximum spacing of forty feet (40').

5.0040 - BACKFLOW PREVENTION

Back flow prevention devices shall be required on all 1-1/2" and larger water services as provided for in Oregon Administrative Rules, Chapter 333, and as directed by the Public Works Director.

5.0050 - WATER SERVICE LINES

The sizes of water service lines which may be used are 3/4", 1", 2", 4", 6", 8", 10", and 12". Water service lines will be reviewed for effects on the distribution system and shall not be greater in size than the distribution main.

For two-inch (2") and greater services, a design drawing must be submitted showing the vault and fitting requirements with the expected flow (normal and maximum daily flow) requirements and proposed usage.

Domestic service lines 3/4" through 2" shall normally extend from the main to behind the sidewalk with a meter setter and meter box located at the termination of the service connection. The face of the meter box shall be no closer than 6" to the sidewalk. Meters shall be provided and installed by City at the cost of the developer. Meter boxes are to be provided by the developer. In general, individual service connections shall terminate in front of the property to be served and shall be located two feet (2') on each side of a common property line.

When the service line is 1" or less, a concrete Brooks meter box shall be provided. Larger meter boxes shall be set as directed by the Public Works Director.

Fire Service - There are three categories of private fire services: 1) hydrants, 2) fire sprinkler lines, and 3) combination hydrant and fire sprinkler lines.

The water fire service line shall normally extend from the main to the property line and end with a vault, metering device and valves. A double detector check back flow prevention device installed in a vault shall be required at each property being served.

Fire Vaults - A vault will be required when a development provides fire sprinklers. The vault drawing will be included on construction drawings submitted to the City. The vault shall contain all valves, fittings, meters, and appurtenances required for fire service to the development.

5.0060 - SYSTEM TESTING

All new water systems (lines, valves, hydrants, & services) shall be individually pressure tested, chlorinated and tested for bacteria. All testing shall be performed in accordance with the latest edition of the Oregon Chapter APWA Standard Specifications for public works construction, OAR's and in the presence of a City water department representative.

5.0070 - EROSION CONTROL

Erosion control will be required for all areas disturbed during construction and following construction until permanent protection is established.

Temporary facilities may include silt fences, drain barriers, gravel entries, ditches, surface stabilization or other devices as necessary.

Temporary/permanent hydro-seeding or acceptable seeding and mulching must be provided whenever perennial cover cannot be established on sites which will be exposed after September 1 or prior to June 1.

CITY OF MOLALLA PUBLIC WORKS DESIGN STANDARDS

SECTION 6.0000 - STREETS

6.0010 - GENERAL DESIGN REQUIREMENTS

Performance Standards - All street designs shall provide for the safe and efficient travel to the motoring public. Streets shall be designed to carry the recommended traffic volumes identified for each street classification. Street classifications are set forth in Section 6.0110 STREET SYSTEM DESCRIPTION AND FUNCTION.

Streets shall be designed to meet or exceed minimum guidelines. These guidelines are set forth in the "AASHTO Policy on Geometric Design of Highways and Streets" (latest edition). Traffic Control Devices shall conform to the "Manual on Uniform Traffic Control Devices for Streets and Highways," Federal Highway Administration, with Oregon Supplements, Oregon Dept. of Transportation's (latest edition).

All vertical and horizontal curves shall meet the guidelines of the AASHTO Policy and the design speed for each street classification. Where practical, the Design Engineer shall provide the desirable stopping sight distance set forth in the AASHTO Policy. But in no case shall it be less than the minimum stopping sight distance given be permitted.

Standard drawings relevant to this section may be found in the most current edition of the APWA Standard Specifications for Public Works Construction, Oregon Chapter.

6.0011 - RIGHT-OF-WAY AND PAVEMENT WIDTH

Right-of-way and minimum pavement widths for each street classification shall be as follows:

Type of Street	Right-of-Way	Roadway
Arterial	75	44
Commercial and Industrial	60	36
Collector	60	36
Minor	50	36
Radius of Turnaround at End of Cul-de-Sac	50	45
Noncontinuous Aligning Street Not Exceeding 1000'	50	20
Alley	20	20

Where conditions, particularly the size and shape of land parcels, make it impractical to provide minimum lot sizes if the standard street widths are used, right-of-ways of not less than fifty feet may be accepted for minor streets which do not have a continuous alignment exceeding one thousand eight hundred feet and for cul-de-sacs.

6.0012 - ACCESS

All development shall be provided public street access. Access roads - public and/or private, driveways, and easements shall be as set forth in other sections of these Design Standards.

6.0013 - TRAFFIC ANALYSIS

The Public Works Director will require a traffic analysis report as determined by the type of development and its potential impact to existing street systems. A traffic analysis may be required for a development 1) when it will generate 1,000 vehicle trips per weekday or more, or 2) when a development's location, proposed site plan, traffic characteristics could affect traffic safety, access management, street capacity, or known traffic problems or deficiencies in a development's study area, or 3) for any development of four residential dwelling units and larger (whether a fourplex or four single family units)..

The report will be prepared by a licensed traffic engineer in the State of Oregon. At a minimum, the report shall contain the following:

1. Purpose of Report and Study Objectives

A discussion of key traffic issues to be addressed and the transportation system and development objectives related to a specific development.

General transportation system objectives are:

- o to maintain easy and safe traffic flow on surrounding street system
- o to provide effective and safe transfer of vehicle traffic between the site and the street system to provide convenient, safe and efficient on-site and off-site movement of vehicles, pedestrians, transit, service and delivery vehicles, and bicycle
- o to effectively mitigate adverse site-generated traffic impacts on affected streets and intersections. Site-specific objectives may be established by the City for each study.

2. Executive Summary

A concise summary of the study purpose/objectives, site location and study area, development description, key assumptions, findings, conclusions and recommendations.

3. Description of Site and Study Area Roadways

A description of the site and study area, existing traffic conditions in the study area, and anticipated nearby development and committed roadway improvements which would affect future traffic in the study area.

The study area will be defined by:

All roads, ramps and intersections through which peak hour site traffic composes at least 5% of the existing capacity of an intersection approach, or roadway sections on which accident character or residential traffic character is expected to be significantly impacted.

On-site Traffic Evaluation

An evaluation of the proposed (and alternative) site access locations, the adequacy of access drive depth, driveway lanes, and queuing storage, the safety and efficiency of proposed vehicular circulation, parking layout, pedestrian and service vehicle routes/facilities, together with recommendations for on-site traffic markings and controls.

1. Technical Appendix

A technical appendix including work sheets, charts, traffic count, drawings to support findings as described in the body of the report.

2. Recommendations for Public Improvements

Recommendations should be made for external roadway improvements, such as additional through lanes and turn lanes, and traffic control devices necessitated as a

result of the development. Recommended improvements to transit facilities, and pedestrian and bike circulation should also be reported.

The recommendations should specify the time period within which improvements should be made, particularly if improvements are associated with a phased development, the estimated cost of improvements, and any monitoring of operating conditions and improvements that may be needed. If needed street improvements, unrelated to the development, are identified during the analysis, such improvements should be reported.

3. Access Management

On sites with arterial and collector street frontages, the report shall evaluate and recommend the use of access management plans or techniques:

To separate basic conflict areas. Reduce number of driveways or increase spacing between driveways and intersections.

To remove turning vehicles or queues from the through lanes. (Reduce both the frequency and severity of conflicts by providing separate paths and storage area for turning vehicles and queues.) These techniques may include turn restrictions, striping, medians, frontage roads, channeling of lanes or driveways, shared driveways and access between similar uses, access consolidation, lanes for left or right turns, and other transportation system management (TSM) actions.

4. A review of alternative access points for site access to highways, city streets, and county roads.

5. The analysis of alternate access proposals should include:

- a. Existing daily and P. M. peak hour counts, by traffic movements, at intersections effected by generated traffic from the development. (Use traffic flow diagrams).
- b. Projected daily and P.M. peak hour volumes for these same intersections and proposed access points when the development is in full service. (Use traffic flow diagrams.)
- c. A determination of the existing levels of service and projected levels of service at each intersection and access points studied.
- d. A discussion of the need for traffic signals. This should include a traffic warrant computation based on the National Manual on Uniform Traffic Control Devices.
 1. The recommendations made in the report should be specific, and should be based on a minimum level of service when the development is in full service. As an example, if a traffic signal is recommended, the recommendation should include the type of traffic signal control and what movements should be signalized. If a storage lane for right turn or left turn is needed, the recommendation should include the amount of storage needed. If several intersections are involved for signalization, and an interconnect system is considered, specific analysis should be made concerning progression of traffic between intersections.
 2. The report should include a discussion of bike and pedestrian usage and the facilities provided along with the availability of mass transit to serve the development, if appropriate.

6.0014 - INTERSECTIONS

Connecting street intersections: shall be located to provide for traffic flow, safety, and turning movements, as conditions warrant.

Arterial Intersections: Exclusive left and right turn lanes will be provided, bus turnouts will be provided if traffic flow and safety conditions warrant, designated crosswalks will be provided at controlled locations and street alignments across intersections shall be continuous.

Collector and Local Street Intersections: Street and intersection alignments should facilitate local circulation but avoid alignments that encourage non-local through traffic.

Streets shall be aligned so as to intersect at right angles (90°). Angles of less than 75° will not be permitted. Intersection of more than two streets at one point will not be permitted.

New streets shall intersect with existing street intersections so that centerline is not offset, except as provided below. Where existing streets adjacent to a proposed development do not align properly, conditions may be required of the development to provide for proper alignment.

For intersections which are not directly aligned with street centerline, the centerline spacing must meet the following minimum separation distance:

<u>Street Class</u>	<u>Intersection Spacing (ft)</u>
Arterial	500*
Collector	400*
Local	300*
Cul-de-sac	150

* The Public Works Director may permit a minimum spacing of not less than 300 feet (Arterial), 200 feet (Collector), 200 feet (Local), when findings are made to establish that:

- a. Without the change, there could be no public street access from the parcel(s) to the existing street, and
- b. All other provisions of the street design requirements can be met.

6.0015 - HALF-STREET CONSTRUCTION

Half-street construction is generally not acceptable. Where such a Street is justified, the right-of-way and pavement width will be approved by the Public Works Director. In no case shall the pavement width required be less than that required to provide two lanes of traffic to pass at a safe distance. For a 32-foot local street the half-street pavement width will be 20-feet. Half-streets will only be approved when the abutting or opposite frontage property is undeveloped and the full improvement will be provided with development of the abutting or opposite (upon right-of-way dedication) frontage property. Half-street improvements shall include curb, sidewalk and storm drainage on one side of the street. When a half-street improvement is required, the entire street shall be designed

A development on an unimproved street shall be responsible for constructing a continuous City standard street to a connection with the nearest standard (publicly-maintained) street.

6.0016 - STREET CLASSIFICATION

All streets within the City shall be classified as listed in Section 6.0110 STREET SYSTEM DESCRIPTION AND FUNCTION. The classification for any street not listed shall be that determined by the Public Works Director.

6.0017 - DESIGN SPEED

Design speeds for classified streets shall be as follows:

Arterial	35-45 mph
Collector	30-40 mph
Local	25 mph
Cul-de-sac	25 mph

6.0020 - HORIZONTAL/VERTICAL CURVES, AND GRADES

6.0021 - HORIZONTAL CURVES

Horizontal curve radius (on centerline) for each street classification shall be designed according to the roadway design speed. The radius shall not be less than the following:

Arterial	415-600'
Collector	165-275'
Local	100'
Cul-de-sac	100'

6.0022 - VERTICAL CURVES

Vertical curve length shall be based on the design criteria which includes: (1) design speed, (2) crest vertical curve, and (3) sag vertical curve. Stopping sight distance for crest and sag vertical curves shall be based on sight distance and headlight sight distance, respectively.

All vertical curves shall be parabolic and the length shall be computed for each location.

6.0023 - GRADES

Maximum grades for each street classification shall be as follows:

Arterial	0.060 ft/ft
Collector	0.080 ft/ft
Local	0.100 ft/ft
Cul-de-sac	0.120 ft/ft

Local and cul-de-sac streets may exceed 12%, but in no case permitted to exceed 16%. The Public Works Director may approve a grade greater than 12% when all of the following conditions exist:

1. Topographic constraints do not allow the development to be served by a street with a maximum grade of 12% without causing de-stabilization of soils by excessive cuts and fills.
2. There is no access to the property being developed through adjacent properties at a maximum 12% grade.
3. The section of local street will not exceed a combination of length, horizontal alignment, and/or grades exceeding 12% which will create hazardous traffic conditions.
4. In no case shall the maximum street grade exceed 16%.

Minimum grade for all streets shall be 0.0050 feet per foot (0.50%) however, in all cases, street grades shall allow for proper and adequate drainage. Cul-de-sac "bulbs" shall have a minimum slope of 0.0060 feet per foot (0.60%).

Street cross-slopes shall be two (2) percent. Where there are site constraints the cross slope can vary from one (1) to three (3) percent.

The pavement section shall consist of:

1. Filter fabric over subgrade.
2. 8 inches 3/4 -0 base aggregate.
3. 1-1/2-inch lift of AC installed immediately.
4. Additional 1-1/2-inch lift of AC installed after one year at the developer's expense.

6.0024 - STREETS - EXISTING

Whenever existing streets adjacent to or within a tract are of inadequate width, additional right-of-way shall be provided at the time of subdivision (Ord. 1980-7 S6.2(G)).

6.0025 - STREETS - NAMES

No street name shall be used which will duplicate or be confused with the names of existing streets, except for extensions of existing streets. Street names and numbers shall conform to the established pattern in the City, and shall be subject to the approval of the City (Ord. 1980-7 S6.2(J)).

6.0026 - STREETS - ADJACENT TO RAILROAD RIGHT-OF-WAY

Wherever the proposed subdivision contains or is adjacent to a railroad right-of-way, provision may be required for a street approximately parallel to and on each side of such right-of-way at a distance suitable for the appropriate use of the land between the streets and the railroad. The distance shall be determined with due consideration at cross streets of the minimum distance required for approach grades to a future grade separation and to provide sufficient depth to allow screen planting along the railroad right-of-way (Ord. 1980-7 S6.2(L)).

6.0027 - STREETS - MARGINAL ACCESS

Where a subdivision abuts or contains an existing or proposed arterial street, the hearings officer may require marginal access streets, reverse frontage lots with suitable depth, screen planting contained in a nonaccess reservation along the rear or side property line, or such other treatment as may be necessary for adequate protection of residential properties to afford separation of through and local traffic (Ord. 1980-7 S6.2(M)).

6.0030 - PAVEMENT DESIGN

In general, all streets shall be constructed with asphaltic concrete type "C"; however, Portland Cement Concrete (PCC) streets are permitted as approved by the Public Works Director.

Raising manhole rings, valve boxes, catch basins, etc. to final grade shall be at the developer's expense.

The Engineer will provide a street structural design section for all roadways classified Neighborhood Collector and higher, and local streets in industrial zones. A structural design section will also be required when the soils report indicates poor soil.

6.0040 - CONCRETE CURB

All development projects will be required to construct street improvements with concrete curbs. Standard Curb shall only be used on streets classified Collector and lower when the longitudinal street grade is 0.10 feet per foot (1.0%) or greater. All others curbs and sidewalks shall be abutting. Monolithic Curb and Gutter shall be used on streets classified Collector and higher and when the longitudinal street grades less than 1.0%. Curb exposure for Standard Curb is five (5) inches, and seven (7) inches at catch inlets. Curb exposure for monolithic curb and gutter shall be six (6) inches, and eight (8) inches at catch insets. Joint spacing in curbs shall be 15-foot maximum for contraction joints and 45-foot maximum for expansion joints. In addition, expansion joints shall be located at all curb return Points and at driveway curb drop transition points.

A minimum of two drainage block-outs to accommodate 3" drain pipe shall be provided for each lot. Typically, these block-outs are located five feet (5') from each side property line.

6.0041 - CURB RETURN RADIUS

Curb return radius at street intersections shall be designed to accommodate all expected traffic. Minimum curb radius required shall be as follows:

<u>Intersection</u>	<u>Radius</u>
Local/Cul-de-sac with Local/Cul-de-sac	20'
Local/Cul-de-sac with Collector	20'
Local/Cul-de-sac with Collector or Arterial	30'
Collector with Collector or Arterial	30'
Collector/Arterial with Collector/Arterial	30'

Streets serving commercial/industrial properties may be required to install larger curb radius as required for vehicle movements.

6.0050 - PARKING

<u>Street Class</u>	<u>Parking Lanes</u>	<u>Parking Required</u>
Arterial	None	May be allowed in some areas
Collector	2	Variable (a)(b)
Local	2	Yes (c)(d)
Cul-de-sac	2	Yes (c)(d)

- a. Where bike lanes exist on collectors, parking may be prohibited.
- b. Collector - No parking within 45' of curb return.
- c. Local - No parking within 30' of curb return.
- d. Local Streets and Cul-de-sacs which are approved for reduced 40 feet right-of-way and 28 feet pavement, will be required to have one parking lane to assure that on-street parking is adequate for adjacent uses, a reduced street design will consider clustered parking bays adjacent to the street, if needed. Parking will not be allowed in a reduced radius cul-de-sac bulb.

For streets designated collector and below, the Public Works Director may consider design modifications to conserve major trees in the public right-of way. Subject to approval by the Public Works Director, parking lanes may be removed on one or on both sides of a street.

Design standards - parking and loading.

- a. Scope.
 - 1. These design standards shall apply to all parking, loading and maneuvering areas.
 - 2. All parking and loading areas shall provide for the turning, maneuvering and parking of all vehicles in the lot.

b. Access.

1. Where a parking or loading area does not abut directly on a public street there shall be provided an unobstructed drive and not less than 20 feet in width for two-way traffic, leading to a public street, and traffic directions shall be plainly marked.

Parking area improvements. All public or private parking areas which contain three or more parking spaces and outdoor vehicle areas shall be improved according to the following.

- a. All parking areas shall have durable, dust free surfacing of asphaltic concrete, Portland cement concrete or other approved materials. The design section shall conform to the use and the soils report. All parking areas, including those in conjunction with a single family or two-family dwelling, shall be graded so as not to drain excess storm water over the public sidewalk or onto any abutting public or private property.
- b. All parking areas, except those required in conjunction with single family or two-family dwellings or vehicle sales areas, which abut a residential district, shall conform to the screening requirements as set forth in the city's site design ordinance.
- c. All parking areas, except those required in conjunction with single family or two-family dwellings or vehicle sales areas may contain a maximum of 25% of the parking spaces sized for compact vehicles.
- d. All required handicapped parking space shall conform to the Americans With Disabilities Act (ADA), ORS 447.210, and City Parking Standards and shall be a minimum of 14 feet in width.
- e. All parking areas, except those required with single family or two family dwellings or vehicle sales areas, shall have physically marked individual parking spaces such as painted lines, lettering, curbs and landscaping.

Table of Standards. The following table provides the minimum dimensions of parking stall's, length and width, aisle width and maneuvering space, of public or private parking areas. All parking facilities shall meet these minimum standards. The width of each parking space includes a four inch (4") wide stripe which separates each space. Compact spaces are noted in parenthesis:

Angle from Curb	Stall Width "A"	Channel Width "B"	Aisle Width "C"	Curb Length per stall "D"
Parallel	9' 0" (8' 6")	9' 0" (8' 6")	12' 0" (12' 0")	23' 0" (20' 0")
30°	9' 0" (8' 6")	16' 10" (14' 10")	12' 0" (12' 0")	18' 0" (17' 0")
45°	9' 0" (8' 6")	19' 1" (16' 7")	14' 0" (14' 0")	12' 9" (12' 0")
60°	9' 0" (8' 6")	20' 1" (17' 3")	18' 0" (18' 0")	10' 5" (10' 3")
90°	9' 0" (8' 6")	18' 0" (15' 0")	24' 0" (24' 0")	9' 0" (8' 6")

6.0060 - SIDEWALKS

In general, new sidewalks are required for all development requiring a development permit.

Minimum Sidewalk Width

<u>Street Class/Location</u>	<u>Includes 6" curb</u>	
Arterial	6'	
Collector	5' 6'	Residential Commercial/Industrial
Local	5' 5' 6'	Residential 40' R/W - Residential Commercial/Industrial
Cul-de-sac	5' 5' 5'	Residential 40' R/W - Residential Commercial/Industrial

Sidewalks include a six inch curb as a portion of the minimum width. Sidewalks may be required to meander within the dedicated right-of-way or outside of the right-of-way within an easement with the approval of the Public Works Director.

For streets designated collector and below, the Public Works Director may consider design modifications to conserve major trees in the public right-of-way. Subject to approval by the Public Works Director, sidewalks may be deleted on one side of a street.

6.0061 - WHEELCHAIR RAMPS

Each corner at all intersections shall contain wheelchair ramps for handicapped access located within the curb return. Ramps shall also be located wherever an accessible route crosses a curb. In residential areas the ramp will be located at the midpoint of the curb return. On streets classified above local or cul-de-sac, ramps may be required at different locations within the curb return. It may also be required to construct two (2) ramps at a curb return when a different location is required.

Locations of sidewalk ramps shall be designed with regard to storm water flows, street grades, and pole locations. Other factors may also dictate sidewalk ramp location. Wheelchair ramps shall be designed to conform with the requirements of the Americans with Disabilities Act (ADA).

6.0070 - BIKEWAYS

This summarizes the City's policy and implementation strategies for bike ways within the City and for connection with metropolitan bike ways. The City's plan has adopted both AASHTO and ODOT standards and criteria as the minimum guidelines for bike way design, construction and control.

The City's adopted guidelines for bike ways consist of the following:

1. Guide for Development of New Bicycle Facilities 1981
2. AASHTO, Oregon Supplements and Exceptions to AASHTO Guide
3. Manual on Uniform Traffic Control Devices with Oregon supplements by Oregon Transportation Commission

6.0071 - BIKEWAY LOCATION, WIDTH

<u>Bikeway Location</u>	<u>Minimum Width</u>	<u>Comments</u>
Public Street (designated bike lane)	8' **	Each direction of travel
Public Street (non designated bike lane)		One way pavement width greater than 12' - desirable one way pavement width is 14' or greater
Off-Street Bicycle Path	5' *	One-Way Travel
Off-Street Bicycle Path	8'-10' *	Two-Way Travel
Off-Street Bicycle Path (Shared with Pedestrians)	12'*	Two-Way Travel
Off-Street Bicycle Path (Shared with Pedestrians)	7'	One-Way Travel

* Paths are constructed with 2' gravel shoulders on both sides.

** An eight-foot section is required unless this width is not practical because of physical or economic constraints. A minimum width of four feet may be designated as a bicycle lane.

6.0072 - DESIGN CRITERIA

In general, bikeway design shall meet the adopted standards referred to in Section 6.0060.

All bike ways shall have a minimum cross slope of two percent (2%) and a maximum cross-slope of five percent (5%). On curved alignments, the cross-slope shall be to the inside of the curve.

Bikeway curvature will be based on a minimum design speed of 20 mph. Bikeway grades shall be limited to a maximum of five percent (5%). Where topography dictates, grades over five percent (5%) are acceptable when a higher design speed is used and additional width is provided.

6.0073 - CONSTRUCTION

Off-street bike ways shall be constructed for two different situations. The two situations are: Where limited maintenance vehicle (City-owned) use will occur, and where heavy maintenance vehicle use will occur. In both cases, sub grade preparation will require removal of existing organic material and compaction.

<u>Use</u>	<u>Bikeway Thickness</u>	
	<u>Asphalt</u>	<u>Aggregate</u>
Limited	2"	6"
Heavy	3"	8"

When drainage, such as side ditches, is required parallel with the bike way, the ditch centerline shall be at least five feet (5') from the edge of the pavement. Ditch side slope adjacent to the bike way shall be no steeper than 2:1 when measuring the horizontal distance to the vertical distance.

When culverts cross bike ways, the ends of the pipe shall be no closer than five feet (5') from the edge of the bike way.

6.0074 - LIGHTING

Lighting should be included in the bikeway design when nighttime security could be a problem and a high nighttime use is expected (i.e., paths serving students, commuters). The horizontal illumination levels shall be .05 foot candle (5 lux) to 2 foot candles (22 lux) except when security problems exist. Higher illumination levels should be considered in these locations. The placement of the light standards (poles) shall meet all vertical and horizontal clearances.

6.0075 - DETERRING MOTOR VEHICLE USE

Bike paths intersecting with roadways require physical barriers to deter use by unauthorized motor vehicles. A lockable, removable post(s) may be used to discourage such use and still permit authorized vehicles to access the paths. The post shall be brilliantly colored and permanently reflectorized. If more than one (1) post is required, the spacing shall not exceed a separation of more than five (5) feet.

An alternative to deterring the motor vehicles is to design two (2) five (5) foot wide lanes separated by low landscaping at the intersection.

6 0080 - DRIVEWAYS

Access to private property shall be permitted with the use of driveway curb cuts. The access points with the street shall be the minimum necessary to provide access while not inhibiting the safe circulation and carrying capacity of the street.

On Collector streets and above, one driveway per site frontage will be the normal maximum number. Double frontage lots and corner lots on these streets may be limited to access from a single street, usually the lower classification street. If additional driveways on a frontage are approved by the Public Works Director, a finding shall be made that no eminent traffic hazard would result and impacts on through traffic would be minimal. Restrictions may be imposed on additional driveways, such as limited turn movements, shared access between uses, closure of existing driveways, or other access management actions.

Driveway approach types including residential driveway, commercial/industrial driveways, must be approved by the Public Works Director.

Should the length of a driveway be greater than fifty (50) feet in length and the driveway has only one (1) access to the street or does not loop to the street, a turnaround shall be provided. The minimum inside radius of the turn around shall be fifteen (15) feet with a width at the turnaround point of thirty (30) feet for maneuvering.

TABLE 6 - I
Driveway Widths (Min-Max)

<u>Street Class.</u>	<u>Residential</u>	<u>Commercial</u>	<u>Industrial</u>	<u>No. Allowed</u>
Arterial	12/24(2)	12/36	12/36	Res.-1/250' frontage Com.- 1/250' frontage
Collector	12/24(2)	12/36	12/36	Res.-1/frontage Com.- 1/frontage(5)
Local	12/24(2)	12/36	(4)	Res.-1/frontage(3) Com.-1/frontage
Cul-de-sac	12/24(2)	12/36	12/36	Res.-1/frontage(3) Com.- 1/frontage

Res. = Residential Zone Com.= Commercial Zone Ind.= Industrial Zone

- Notes: (1) Special conditions may warrant access.
(2) 28' maximum with 3 car garage.
(3) Frontage greater than 130' permitted one additional curb cut.
(4) Build to Collector standard.
(5) Certain businesses may warrant one additional curb cut for service driveways.

TABLE 6 - 2
Driveway Locations (minimum distance to curb return)

<u>Street Classification</u>	<u>Residential</u>	<u>Commercial</u>	<u>Industrial</u>
Arterial	100' (1)(3)	100'	100'
Collector	45' (3)	100'	100'
Local	45' (2)	45'	45'
Cul-de-sac	45' (2)	45'	45'

- Notes: (1) Minimum distance from curb return unless this prohibits access to the site.
 (2) 25 feet will be allowed for corner lots with limited frontage where distance requirements cannot be met.
 (3) Direct access to this street will not be allowed, if an alternative exists or is planned.

For classification of Collector and above, driveways adjacent to street intersections shall be located beyond the required queue length for traffic movements at the intersection. If this requirement prohibits access to the site, a driveway with restricted turn movements may be allowed.

Within commercial, industrial and multi-family areas shared driveways and internal access between similar uses are encouraged to reduce the access points to the higher classified roadways, to improve internal site circulation, and to reduce local trips or movements on the street system. Shared driveways or internal access between uses will be established by means of common access easements at the time of development.

Driveway grades shall not exceed twelve percent (12%) from the curb line to the property line.

6.0090 - STREET LIGHTING, NAMES AND SIGNAGE

6.0091 - STREET LIGHTING

A complete street lighting system shall be the responsibility of the development. All streets fronting the property shall be provided with adequate lighting. Developer is required to provide lighting for public convenience and safety. For lighting requirements, all developments will be required to submit three (3) copies of the final plat (residential and major land partitions) to the Public Works Director. Commercial and industrial developments, in addition to the above requirement, shall submit three (3) copies of the site plan to the Public Works Director.

Street lighting shall be provided as part of the street design process. Design illumination levels shall be in accordance with the recommendations of the "Illuminating Engineering Society" and are summarized in the following table.

RECOMMENDATIONS FOR ROADWAY AVERAGE
MAINTAINED HORIZONTAL ILLUMINATION

<u>Roadway Classification</u>	<u>Commercial</u>	<u>Urban Intermediate</u>	<u>Residential</u>
	<u>Foot Candles</u>		
Highway	1.4	1.2	1.0
Arterial	2.0	1.4	1.0
Collector	1.2	.9	.6
Local/Cul de sac	-	.9	.6

The average-to-minimum uniformity ratios for roadways in commercial and intermediate areas shall be 4:1 or better. In residential areas this uniformity ratio shall be 6:1 or better.

The street lighting system shall be provided using high pressure sodium vapor luminaries. The design average horizontal illumination and uniformity ratio shall be obtained by considering together the factors of lamp wattage, pole support spacing, and luminaire height of the street lights. It is preferred to locate poles at lot line extensions and not in the middle of a lot, and to locate poles at corners.

6.0092 - STREET NAMES AND TRAFFIC CONTROL

Street names for all new development will be approved by the City prior to recording of any maps or plats. The development shall pay for all street name and traffic control signage prior to the signing of the final plat or map by the City. All new Signage will be provided and installed by the developer and installed by the City in new developments.

Street names shall conform with the established grid system(s) in the City and its UGB. No new street name shall be used which will duplicate or be confused with the name of existing streets in the UGB area.

Building numbering will be issued by the City of Molalla.

6.0100 - MAILBOXES

Joint mailbox facilities shall be provided in all residential developments, with each joint mailbox serving at least two (2) dwelling units.

1. Joint mailbox structures shall be placed adjacent to roadway curbs.
2. Proposed locations of joint mailboxes shall be designated on as part of the development plan, and shall be approved by the Public Works Director.
3. Plans for the joint mailbox structure to be used shall be submitted as part of the development plan for approval by the Public Works Director.

6.0110 - STREET SYSTEM DESCRIPTION AND FUNCTION

6.0111 - GENERAL GUIDELINES

The urban boundary map, policies and access requirements for various land uses, as adopted by the Comprehensive Plan and Zoning Ordinance, shall serve as guidelines for the functional classifications, definitions and standards requirements and rules adopted under this chapter.

6.0112 - FUNCTIONAL CLASSIFICATIONS

Functional classification categorizes roads and streets by their operational purpose. Some of the key factors considered when adopting the functional classifications were the following:

- a. Relation between street traffic and land use of the abutting properties;
- b. Volume and kinds of traffic;
- c. Relative origins and destinations of traffic and lengths of trips.

The basic hierarchy of functional classification is Arterial streets, Collector streets and Local streets and Cul-de-sac streets. These categories are defined as follows:

Arterial streets: Arterial streets carry higher volumes of traffic, usually over 4,000 vehicles/day and are generally consist of three or more lanes, with the third lane being a common turn lane. Their function is to serve intra-county trips; that is, trips which have at least one end trip within the county.

Collector streets: Collector streets gather area traffic from local streets within a one-half mile radius and connect it to the arterial system. They are not intended to serve through traffic, and they are the lowest order of streets designed to carry transient vehicles. Collector streets generally have a traffic volume rate of 1,000 to 4,000 vehicles/day. Abutting land uses are generally residential.

Local streets: Local streets provide access to abutting property and do not serve to move through traffic. Local streets standards will be further categorized by adjacent land use into residential, commercial and industrial local streets.

Local streets - (Commercial/Industrial): Within the local street classification, there may be considerable difference between the kind of improvement specified where commercial or industrial land uses access a local street, as compared to the kind of improvement specified for residential access. Generally, a local street classification in commercial or industrial areas will require an improvement equal to that specified for a collector classification.

Cul-de-sac streets: Cul-de-sac streets provide access to abutting property only and will be as short as possible, in no event shall a Cul-de-sac be more than 450' in length.

The length of a Cul-de-sac shall be measured along the centerline of the roadway from the near side of the intersecting street to the farthest point of the Cul-de-sac. All Cul-de-sac streets shall terminate in a circular turnaround.

6.0120 - PERMANENT DEAD-END STREETS

A standard cul-de-sac turnaround shall be provided at the end of a permanent dead-end street that does not provide looped circulation. Permanent dead-end streets shall be limited to serving no more than eighteen dwellings and shall not exceed 450' in length from the point of the nearest centerline/centerline intersection.

A permanent dead-end street is measured from the right-of-way line at the nearest intersecting street, which has at least two points of access, to the right of way line at the furthest end of the dead-end street.

An existing dead-end street system which is more than 450' long or which serves more than 25 dwelling units may be terminated in a cul-de-sac if no Future Street Plan has been adopted and the following criteria are met:

- a. Alternative emergency vehicle access or fire protection is provided satisfactory to the local Fire Authority and,
- b. Neighborhood traffic circulation needs are not adversely impacted by the proposed cul-de-sac termination of the street.

Temporary dead-end streets more than one-hundred-fifty (150) feet in length shall be provided with an approved turn-around for emergency vehicles.

6.0130 - ALLEYWAYS AND PRIVATE RESIDENTIAL STREETS/ACCESS WAYS

6.0131 - ALLEYWAYS

Alleyways may be provided in commercial and industrial developments with approval by the Public Works Director. When approved, alleyways shall be dedicated to the city. The right of way width shall be 20 feet with a 20 foot pavement width.

Design for alleyways shall meet the same criteria as other public streets. The exceptions to those criteria may be centerline radius and design speed. Generally, alleyways shall be designed for one-way operations.

6.0132 - PRIVATE RESIDENTIAL ACCESS WAYS

In general, private residential streets and access ways shall only be allowed for multi-family developments such as condominiums and apartments and mobile home parks. Interior design for private access ways in a manufactured home park shall meet standards for private residential access ways including:

1. Dead-end access ways shall not exceed 600 feet in length nor serve more than 25 dwellings units. Dead-end access ways which exceed 150 feet in length shall be provided with an approved turnaround.
2. "Private Street" Signage and driveway approach shall be placed at the intersection with the public street to clearly identify the private access way.

3. Private maintenance of the private streets/access ways shall be provided by a Homeowner's Association or other appropriate entity. Maintenance shall insure continual emergency access at all times.
4. Location of private access ways shall meet the Uniform Fire Code and meet the minimum pavement section of local residential streets.

6.0133 - PAVEMENT CUTS

Where pavement is installed next to existing pavement and at all trench cuts, the existing pavement shall be saw cut. The face of the joint between the new and existing pavement shall be coated with asphalt emulsion and the surface of the joint shall be sand sealed.

Where existing pavement is cut for utility or other construction, a permit must be obtained from the City. Backfill shall be Controlled Density Fill (CDF) to within 4 inches of final grade, topped by 4 inches Class C AC.

6.0134 - SHOULDERS

Where sidewalks and pavement end or where there is no curb and sidewalk (such as half-street improvements) shoulder rock shall be provided to grade with the pavement. Shoulder rock shall be a minimum of six (6") inches in depth, thirty six inches (36") wide and shall be 3/4-inch minus crushed.

**CITY OF MOLALLA
PUBLIC WORKS
DESIGN STANDARDS**

SECTION 7.0000 - PERMIT

A permit shall be obtained before beginning construction, alteration or repairs, other than ordinary repairs, using application forms furnished by the City of Molalla.

7.0010 - APPLICATION FOR PERMIT

7.0011 - APPLICATION

To obtain a permit, the applicant shall first file an application therefore in writing on a form furnished by the City of Molalla for that purpose. Every such applicant shall:

- a. Identify and describe the work to be covered by the permit for which application is made.
- b. Describe the land on which the proposed work is to be done by legal description, street address or similar description that will readily identify and definitely locate the proposed building.
- c. Indicate the use or occupancy for which the proposed work is intended.
- d. Be accompanied by plans, diagrams, computations, specifications and other data as required.
- e. State the valuation of any new building or structure or any addition, remodeling or alteration to an existing building.
- f. Be signed by the permittee, or his/her authorized agent.
- g. Give such other data and information as may be required by the building official.

7.0012 - PERMIT FEES

A development fee according to the following schedule and based on the approved certificate of the total development cost, or estimate of the total cost:

<u>On Any Amount Exceeding</u>	<u>But Not Exceeding</u>	<u>Rate</u>
\$0.00	\$5,000.00	\$250.00
\$5,000.00	\$200,000.00	\$250.00 plus 3% of amount in excess of \$5,000.00
\$200,000.00		\$6,100.00 plus 2% of amount in excess of \$200,000.00

7.0013 - EXPIRATION

Every permit issued by the City of Molalla under the provisions of the Codes and/or Ordinances of the City shall expire by limitation and become null and void if the building or work authorized by such permit is not commenced within six months from the issue date of the permit, or if the building or work authorized by such permit is suspended or abandoned at any time after work is commenced for a period of six months. Before work can be resumed, a new permit shall be obtained to do so, and the fee therefore shall be one-half the amount required for a new permit for such work, provided no changes have been made in the original plans and specifications for such work; and provided further that such suspensions or abandonment has not exceeded six months.

A permittee holding an unexpired permit may apply for a one-time extension, provided he/she can show good and satisfactory reasons, and beyond his/her control the work cannot be commenced within the six-month period from the issue date. In order to renew work on a permit after it has expired, the permittee shall pay a new full permit fee.

7.0015 - PENALTY

Any person, firm or corporation violating any of the provisions of the Codes and/or Ordinances of the City, shall be guilty of a misdemeanor and each such person shall be deemed guilty of a separate offense for each and every day or portion thereof during which any violation of any of the provisions of the codes and/or City Ordinances is committed, continued or permitted, and upon conviction of any such violation such person shall be punishable by a fine, or by imprisonment, or by both such fine and imprisonment as established by local applicable laws.

7.0016 - RIGHT OF APPEAL

All persons shall have the right to appeal the building officials decision through a body appointed by the City and qualified by the experience and training to pass upon matters pertaining to building construction.

7.0017 - PLANS

When required by the City, plans shall be drawn to scale and shall be of sufficient clarity to indicate the nature and extent of the work proposed and shall show in detail that it will conform to the provisions of this code and all relevant laws, ordinances, rules and regulations. Plans shall include a plot plan drawn to scale showing the locations of all easements, drainage facilities, adjacent grades, property lines, the proposed building and of every existing building on the property. Two sets of plans required. One additional complete set of plans shall be kept on the job site at all times and made readily accessible to the inspector.

7.0020 - INSPECTIONS

7.0021 - GENERAL

All construction or work for which a permit is required shall be subject to inspection by the City and all such construction or work shall remain accessible and exposed for inspection purposes until approved by the City Inspector. In addition, certain types of construction shall have continuous inspection.

Approval as a result of an inspection shall not be construed to be an approval of a violation of the provisions of the Codes and/or Ordinances of the City of Molalla. Inspections presuming to give authority to violate or cancel the provisions of the Codes and/or Ordinances of the City of Molalla shall not be valid.

It shall be the duty of the permit applicant to cause the work to remain accessible and exposed for inspection purposes. Neither the Building Inspector nor the City of Molalla shall be liable for expense entailed in the removal or replacement of any material required to allow inspection.

A survey of the lot may be required by the City to verify that the structure is located in accordance with the approved plans.

7.0022 - INSPECTIONS FOR RIGHT-OF-WAY IMPROVEMENTS

If the construction of a sidewalk, curb and gutter or A/C improvements, is not included in a performance bond of an approved subdivision or the performance bond has lapsed, then every person, firm or corporation desiring to construct sidewalks as provided by this Section, before commencing the work or improvement, shall comply with the following:

- a. An occupancy permit shall not be issued for a development until provisions of this section are satisfied.

- b. The Public Works Director may allow temporary noncompliance with the provisions of this section to the owner, builder or contractor when, in the engineer's opinion, the construction of the sidewalk is impractical for one or more of the following reasons:
1. Sidewalk grades have not and cannot be established for the property in question within a reasonable length of time;
 2. Forthcoming installation of public utilities or street paving would be likely to cause severe damage to the new sidewalk;
 3. Street right-of-way is insufficient to accommodate a sidewalk on one or both sides of the street; or
 4. Topography or elevation of the sidewalk base area makes construction of a sidewalk impractical or economically feasible.

7.0022 - INSPECTION RECORD CARD

Work requiring a permit shall not be commenced until the permit holder or his/her agent shall have posted or otherwise made available an inspection record card such as to allow the Building Inspector conveniently to make the required entries thereon regarding inspection of the work. This card shall be maintained available by the permit holder until final approval has been granted by the Building Inspector.

7.0023 - INSPECTION REQUESTS

It shall be the duty of the person doing the work authorized by a permit to notify the City that such work is ready for inspection. The City may require that every request for inspection be filed at least one working day before such inspection is desired. Such request may be in writing or by telephone at the option of the City.

It shall be the duty of the person requesting any inspections required to provide access to and means for inspection of such work.

7.0025 - REQUIRED INSPECTIONS

Reinforcing steel or structural framework of any part of any building or structure shall not be covered or concealed without first obtaining the approval of the Building Inspector.

The City of Molalla, upon notification, shall make the following inspections and shall either approve that portion of the construction as completed or shall notify the permit holder or his/her agent wherein the same fails to comply with the code.

7.0030 - INSPECTIONS

7.0031(a) - INSPECTIONS BY THE CITY

1. Site
2. Concrete
 - A. Driveways
 - B. Sidewalks
 - C. Aprons

NOTE: BEFORE ANY CONCRETE IS POURED, ALL FORMS AND REBAR MUST BE INSPECTED.

3. Streets
4. Curbs
5. Street Lights
6. Water Lines
7. Sewer Lines

NOTE: ALL PLANNING REQUIREMENTS MUST BE MET BEFORE ANY PERMITS WILL BE ISSUED